

Research Article

A Fair Resource Allocation Algorithm for Data and Energy Integrated Communication Networks

Qin Yu,¹ Yizhe Zhao,¹ Lanxin Zhang,¹ Kun Yang,² and Supeng Leng¹

¹*School of Communication and Information Engineering, University of Electronic Science and Technology of China, Chengdu 611731, China*

²*School of Computer Science and Electronic Engineering, University of Essex, Colchester, UK*

Correspondence should be addressed to Qin Yu; yuqin@uestc.edu.cn

Received 3 December 2015; Accepted 18 January 2016

Academic Editor: Mianxiong Dong

Copyright © 2016 Qin Yu et al. This is an open access article distributed under the Creative Commons Attribution License, which permits unrestricted use, distribution, and reproduction in any medium, provided the original work is properly cited.

With the rapid advancement of wireless network technologies and the rapid increase in the number of mobile devices, mobile users (MUs) have an increasing high demand to access the Internet with guaranteed quality-of-service (QoS). Data and energy integrated communication networks (DEINs) are emerging as a new type of wireless networks that have the potential to simultaneously transfer wireless energy and information via the same base station (BS). This means that a physical BS is virtualized into two parts: one is transferring energy and the other is transferring information. The former is called virtual energy base station (eBS) and the latter is named as data base station (dBS). One important issue in such setting is dynamic resource allocation. Here the resource concerned includes both power and time. In this paper, we propose a fair data-and-energy resource allocation algorithm for DEINs by jointly designing the downlink energy beamforming and a power-and-time allocation scheme, with the consideration of finite capacity batteries at MUs and power sensitivity of radio frequency (RF) to direct current (DC) conversion circuits. Simulation results demonstrate that our proposed algorithm outperforms the existing algorithms in terms of fairness, beamforming design, sensitivity, and average throughput.

1. Introduction

The strength of network virtualization is upsurge, such as software defined networking (SDN) and collaborative radio access networks (C-RAN). For instance, SDN is expected to transform the way services are created, sourced, deployed, and supported [1–3]. This paper discusses another type of virtualization, namely, a base station, being virtualized into providing not only information transferring but also energy transferring to charge mobile devices. This is largely driven by the fact that mobile devices, while getting more powerful in processing and networking, exhaust their battery more quickly.

To address this challenge, this paper utilizes energy harvesting into wireless communications, namely, the so-called DEINs (Data and energy integrated communication networks). With the development of energy harvesting (EH) technologies and wireless energy transfer (WET) techniques, the DEIN becomes an emerging trend focusing on the study

of wireless power and information cooperation communications [4–7]. Compared with simultaneous wireless information and power transfer (SWIPT) which mainly focuses on the physical layer, DEINs focus on the whole network system, resource allocation, and protocols design in different layers. The typical architecture of a DEIN is shown in Figure 1, which has three major components, that is, a virtual energy base station (eBS), a data base station (dBS), and massive mobile users/mobile devices. The wireless communication is divided into two parts. The virtual eBS first transfers energy to multiple mobile users (MUs) that do not have embedded energy sources via downlink (DL), and then MUs use the harvested energy to perform uplink (UL) wireless information transmission (WIT) to the dBs.

No existent works have taken into account the power sensitivity of RF-DC circuits when DL transfer energy in DEINs, which can lead to a falsely higher data rate when received RF signals cannot be converted into DC (i.e., energy transfer) if their power level is lower than the power sensitivity of an

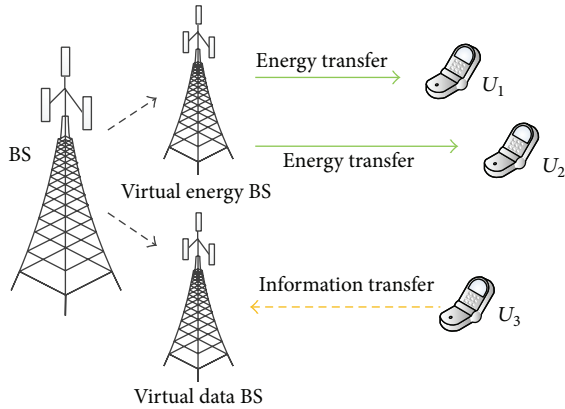

FIGURE 1: A typical architecture of a DEIN based on virtualization.

RF-DC circuit [8]. Besides, none of these works have considered the possibility of energy overflow or the opportunities for users to optimize the use of harvested energy across UL WIT slots. It has been shown that a user using all available energy for WIT in each slot achieves a lower data rate than uniformly distributing energy between energy arrivals [9–11]. Therefore, new dynamic time allocation schemes are needed since not all MUs can harvest energy in every slot, which take into consideration the policy that the energy harvesting of every user should not overflow in every DL WET phase and the energy harvested in the DL WET phase of former slot may be used in the UL WIT of the next.

In this paper, we devise a fair resource allocation algorithm for a DEIN based on dynamical time-slot division to guarantee the received power fairness among all MUs, by maximizing the minimum average DL WET power via optimizing the DL energy beamformer. In particular, considering the power sensitivity of the RF-DC conversion circuits, the virtual eBS transfers energy to these MUs whose estimated received power is larger than the corresponding certain threshold α . The proposed algorithm benefits the following features.

(1) *Fairness.* Since there are more than one user in our scenario, fairness among all MUs should be taken into account naturally. While each MU is allocated the same slot for UL transmission by space-division-multiple-access (SDMA) leading to the fact that the increase or decrease of slot length would lead to similar trend of each MU's throughput, the fairness of the model is mainly reflected by the WET energy beamforming. To achieve the fairness, we aim to allocate the optimal beamformer to maximize the minimum received power among MUs, which can further lead to the fairness of throughput on the whole.

(2) *Sensitivity.* We study the UL transmission powered by WET in a DEIN and model the WET of every user as a Bernoulli process with different probability while taking into account the different sensitivity of RF-DC circuits and calculate the accurate WET probability of different users.

(3) *Throughput Performance.* Considering the sensitivity of RF-DC circuits, that is, the WET probability, we propose a new low complexity resource allocation algorithm to achieve near optimization throughput with finite capacity batteries, which employs the zero-forcing (ZF) based receive beamforming in the UL information transmission [12].

The rest of this paper is organized as follows. Section 2 illustrates some related works about DEINs in recent years. Section 3 presents a multiantenna DEIN model based on virtualization and formulates problems based on fairness. Section 4 presents a dynamic resource allocation to make a near throughput optimization for this problem. Section 5 provides simulation results to compare the performances of proposed solutions with existing algorithms. Finally, Section 6 concludes the paper.

Notations. All lowercased and uppercased boldface letters represent vectors and matrices, respectively. Let $\text{tr}(X)$, $\det(X)$, X^{-1} , and X^H denote the trace, determinant, inverse, and Hermitian of a symmetric matrix X , respectively. \mathbb{C} and \mathbb{R} denote the set of complex and real matrices of size $x \times y$, and \mathbb{C} and \mathbb{R} denote the set of complex and real vectors of size $x \times 1$, respectively. All the $\log(\cdot)$ functions are of base 2 by default and $\ln(\cdot)$ stands for the natural logarithm. All letters at the right bottom of different variables can be explained by the following: l shows the l th slot and i is the different users.

2. Related Works

In this section, we introduce the related energy harvesting-based data-and-energy transmission techniques.

There are so many works focusing on designing resource allocation schemes for different networks. In [13], an energy-efficient context-aware resource allocation problem in caching-enabled ultradense small cells is investigated. In [14], a new analytical performance model is developed to evaluate the QoS of multihop cognitive radio networks. Moreover, we introduce some current researches on DEINs in the following.

SWIPT has been recently studied in the literature (see, e.g., [15–22]), where the achievable information versus energy transmission tradeoffs was characterized under different channel setups. SWIPT, proposed in [15], has been extensively studied, which can offer great convenience to mobile users with concurrent data and energy supplies. SWIPT has been studied in orthogonal frequency division multiplexing (OFDM) systems [16–18] and multiuser channel setups such as relay channels [19, 20] and interference channels [21, 22].

Moreover, another problem, addressing the joint design of DL energy transfer and UL information transmission, is worth investigating [12, 23–25]. UL WIT powered by DL WET in DEINs was studied in [23]. Assuming perfect channel state information (CSI), the single-user DEIN scenario was studied in [23]. The authors maximized the energy efficiency of uplink WIT by jointly optimizing the time duration and transmitted power for downlink WET. Besides, some work is focusing on resource allocation for optimization throughput in DEINs. In [24], a DEIN with single-antenna access point

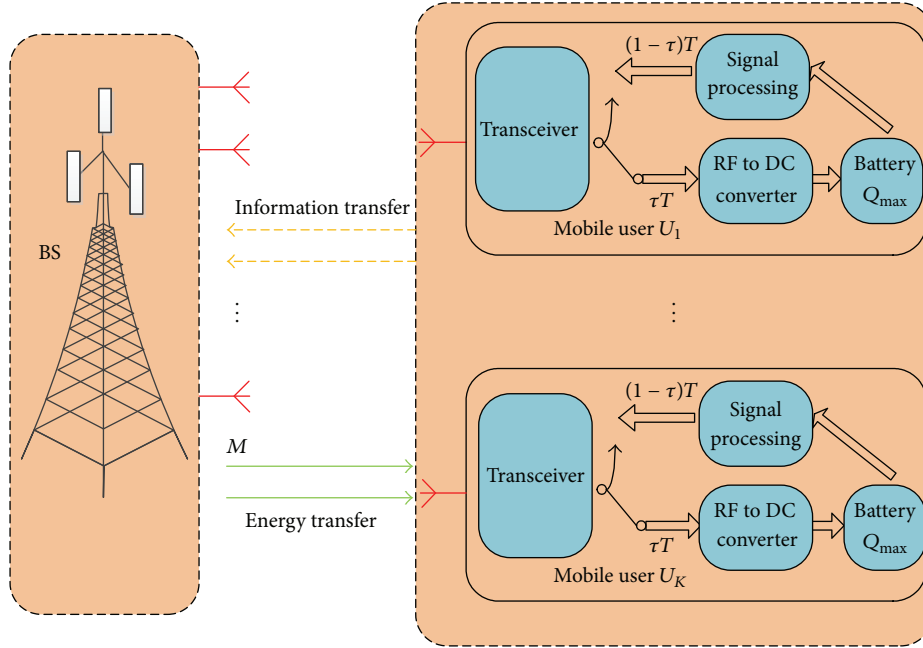

FIGURE 2: A DEIN system model.

(AP) and users has been studied for joint DL energy transfer and UL information transmission. A harvest-then-transmit protocol was proposed and orthogonal time allocations for the DL energy transfer and UL information transmissions of all users are jointly optimized to maximize the network throughput. In [12], a DEIN where one multiantenna AP coordinates energy transfer and information transfer to/from a set of single-antenna users was studied, and the author maximizes the minimum throughput among all users by a joint design of the DL-UL time allocation, the DL energy beamforming, and the UL transmit power allocation, as well as receive beamforming. A WET enabled massive MIMO system with imperfect CSI was studied in [25], where it is based on time-division-duplexing (TDD) protocol and each frame is divided into three phases: the UL channel estimation phase, the DL WET phase, and the UL WIT phase.

But all these works take the idea that the MUs transfer all the received power in DL, ignoring the power sensitivity of RF-DC circuits [9–11]. Besides, no works take the advantage of the battery storage capacity to make a dynamic power allocation, which can have a higher throughput. Even though some works use the parameter (i.e., the battery storage capacity), they also overlook the fact that the capacity cannot overflow when making the resource allocation. In the following, we are going to discuss these questions.

3. System Model and Problem Formulation

In this section, we present a dynamical time slotted transmission scheme and analyze the DL WET phase and UL WIT phase. Finally, we formulate problems based on fairness.

We provide a DEIN model consisting of a BS with M antennas and K single-antenna MUs with finite battery

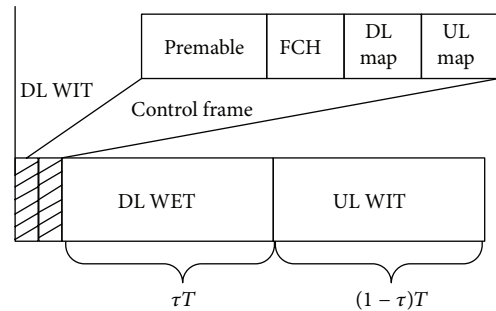

FIGURE 3: Frame structure.

capacity denoted by U_i ($i = 1, \dots, K$), as shown in Figure 2. It is assumed that $M \geq K$. It should be noted that the BS is virtualized into two parts, that is, a virtual eBS and a dBS, as shown in Figure 1. Each MU uses the harvested energy from DL WET phase via beamforming of the virtual eBS to power its UL information transmission via the dBS, under the assumption that two BSs and all MUs are perfectly synchronized and there is no other energy source of MUs. The total capacity of battery storage in every MU is Q_{\max} .

A time slotted transmission scheme is considered as shown in Figure 3. We assume that the period of DL DIT in every slot can be neglected since there is little information to transmit in the DL phase. So, each slot has a constant period T , consisting of two phases, namely, the DL WET phase of duration $\tau \cdot T$ and the UL WIT phase of duration $(1 - \tau) \cdot T$, where $0 \leq \tau \leq 1$. The WET phase starts with several control frames, including the preamble, frame control header (FCH), DL map, and UL map. These frames define transmission parameters, such as coding schemes, available

resources, the duration of DL and UL transmission, and the WET probability (which will be defined in the following). Then, virtual energy BS transmits energy to U_i through wireless energy beamforming. The received power level and the energy harvested at U_i in slot l ($l = 1, \dots, N$) are denoted by $P_{l,i}$ and $E_{l,i}$. It is worth noting that, due to the power sensitivity of RF energy harvesting circuits, U_i cannot harvest any RF energy if the received signal power $P_{l,i}$ is below a certain level. Thus, the received power at every MU can be used if the received power level $P_{l,i}$ is larger than the corresponding certain threshold (e.g., -10 dBm). This indicates that the WET of every MU follows a Bernoulli process with different probability p_i , where p_i stands for the probability of delivering energy from virtual eBS. Next, all MUs do UL WIT phase simultaneously via SDMA, which is powered by the energy stored in the batteries. For simplicity, we assume that $T = 1$ s and that the harvested energy is stored in the battery first and then used for UL information transmission. Note that since the length of control frames is much smaller than that of DL WET and UL WIT, we ignore the time duration of control frames in the following analysis.

We consider frame-based transmissions over flat-fading channels on a single frequency band [26] (i.e., which means the channel remains constant in each slot). Denote $h_{l,i} \in \mathbb{C}^{M \times 1}$ as the UL channel of U_i in the l th slot and we have

$$h_{l,i} = \left(\alpha_0 |D_i|^{-\beta} C_i \right)^{1/2} g_{l,i} \quad i = 1, \dots, K, \quad (1)$$

where α_0 denotes a constant determined by the RF propagation environment, D_i is the propagation distance, β_i is the path loss, C_i is Shadow fading, and $g_{l,i} \in \mathbb{C}^{M \times 1}$ is the matrix of Rayleigh fading coefficients and $g_{k,i} \sim CN(0, 1)$. By exploiting the channel reciprocity, the DL transmission channel can be obtained as $h_{l,i}^H$. For simplicity, we assume that $C_i = 1$ and that CSI is available at both two BSs and U_i .

3.1. DL WET Phase. Assume that just one energy beam is to transmit energy from virtual energy BS to those users satisfying the probability p_i , since we just transmitted energy signals in the DL [27]. Besides, we can allocate the optimal beamformer on the constraint that the power transferred at all of the antennas is equal to the eBS's transmitted power. Hence, we can assume the beamformer as a ratio of P which satisfies the fact that its norm is a unit value, where P is the transmitted power of eBS. Then, the practical power transferred can be denoted as the beamformer multiplied by eBS transmitted power P . Moreover, ambient channel noise energy cannot be harvested. Thus, the DL received signal, received power, and harvested energy of U_i in the l th slot are expressed as

$$y_{l,i} = h_{l,i}^H \omega_l x_{l0} + n_{l,i} \quad i = 1, \dots, K, \quad (2)$$

$$P_{l,i} = x_{l0}^2 h_{l,i}^H \omega_l \omega_l^H h_{l,i} \quad i = 1, \dots, K, \quad (3)$$

$$E_{l,i} = \epsilon_i \tau_l P_{l,i} = x_{l0}^2 h_{l,i}^H \omega_l \omega_l^H h_{l,i} \quad i = 1, \dots, K, \quad (4)$$

where $n_{l,i} \sim CN(0, \sigma_i^2)$ is the receiver noise, ω_l is the $M \times 1$ beamforming and satisfies $\|\omega_l\|^2 = 1$, x_{l0} is the transmission

signal and satisfies $x_{l0}^2 \leq P_{\max}$, where P_{\max} is the transmit power constraint, and ϵ_i denotes the energy harvesting efficiency at U_i , which should satisfy $0 < \epsilon_i \leq 1$. For simplicity, we assume $\epsilon_i = 1$.

3.2. UL WIT Phase. In the UL WIT phase of each slot, MUs use the harvested energy to power UL information transmission to the virtual dBS. For convenience, we assume the circuit energy consumption at U_i is 0. The received signal at the normal dBS in the l th slot is given by

$$y_l = \sum_{i=1}^K h_{l,i} x_{l,i} + n_l \quad i = 1, \dots, K, \quad (5)$$

where $n_l \in \mathbb{C}^{M \times 1}$ denotes the receiver additive white Gaussian noise (AWGN). It is assumed that $n_l \sim CN(0, \sigma_l^2 T)$. Besides, we assume that the normal information BS employs linear receivers to decode $x_{l,i}$ in the UL. $x_{l,i}$ denotes the transmit signal of U_i and satisfies $x_{l,i}^2 = P_{l,i}'$, where $P_{l,i}'$ is the transmit power of U_i . Specifically, let $v_{l,i} \in \mathbb{C}^{M \times 1}$ denote the receive beamforming vector for decoding $x_{l,i}$ and define $V = \{v_{l,1}, \dots, v_{l,K}\}$. In order to reduce complexity, we employ the ZF based receive beamforming in the normal information BS proposed by [12], which is not related to w_l and τ_l . Define $H_{-l,i} = [h_{l,1}, \dots, h_{l,i-1}, h_{l,i+1}, \dots, h_{l,K}]^H$, $i = 1, \dots, K$, including all the UL channels except $h_{l,i}$. Then the singular value decomposition (SVD) of $H_{-l,i}$ is given as $H_{-l,i} = X_{l,i} \Lambda_{l,i} Y_{l,i}^H = X_{l,i} \Lambda_{l,i} [\tilde{Y}_{l,i} \tilde{Y}_{l,i}^H]^H$. Thus, the beamforming can be expressed as $v_{l,i}^{ZF} = \tilde{Y}_{l,i} \tilde{Y}_{l,i}^H h_{l,i} / \|\tilde{Y}_{l,i}^H h_{l,i}\|$. Then, throughput of U_i in bits/second/Hz (bps/Hz) can be expressed as

$$R_{l,i}^{ZF} = (1 - \tau_l) \log \left(1 + \frac{P_{l,i}' \tilde{h}_{l,i}}{\sigma_i^2} \right) \quad i = 1, \dots, K, \quad (6)$$

where $\tilde{h}_{l,i} = \|\tilde{Y}_{l,i}^H h_{l,i}\|^2$.

The energy consumption of UL WIT of U_i in the l th slot is given by

$$q_{li} = (1 - \tau_l) P_{l,i}'. \quad (7)$$

Let $Q_{l,i}$ represent the amount of energy available in the battery of U_i at slot l and its updating function is as follows:

$$Q_{l,i} = \min(Q_{l-1,i} + E_{l,i} - q_{l-1,i}, Q_{\max}). \quad (8)$$

There are two constraints in the UL WIT phase: the energy causality constraint and the battery storage constraint [9, 11]. Specifically, the energy causality constraint requires that the UL WIT can only use the energy harvested at the current and previous slots, and the battery storage constraint indicates that the energy available of U_i cannot exceed the maximum battery capacity at any time; that is,

$$\sum_{l=0}^N [E_{l,i} - q_{l,i}] \geq 0, \quad (9)$$

$$\sum_{l=0}^{N+1} E_{l,i} - \sum_{l=0}^N q_{l,i} \leq Q_{\max}.$$

3.3. Problem Formulation. Considering fairness, we optimize maximum-minimum (max.-min.) average UL WIT throughput of all MUs by jointly optimizing the time allocation τ_l , the DL energy beams ω_l , and the UL transmit power allocation $P'_{l,i}$.

Let $r_{(q_{l,i})}^{\text{ZF}}$ denote the UL data rate of U_i in slot l as a function of the allocated energy $q_{l,i}$ for UL transmission in slot l . Notice that $q_{l,i}$ is a feasible energy allocation policy, which satisfies

$$\begin{aligned} 0 &\leq q_{l,i} \leq Q_{\max}, \\ Q_{l+1,i} &= \min(Q_{l,i} + E_{l+1,i} - q_{l,i}, Q_{\max}), \\ q_{l,i} &= \phi\left(l, \{E_i\}_{m=1}^l\right). \end{aligned} \quad (10)$$

The expression (10) shows energy causality constraint, the battery storage constraint, and causality CSL. We should note that (4) should satisfy the constraint $x_{l_0}^2 \leq P_{\max}$.

Thus, the optimization problem satisfying constraints (10) can be defined as

$$\begin{aligned} \max \min & \lim_{N \rightarrow \infty} \frac{1}{N} \sum_{l=1}^N (1 - \tau_l) \log\left(1 + \frac{P'_{l,i}}{\bar{h}_{l,i}} \sigma_i^2\right) \\ & 0 \leq \tau_l \leq \eta_l, \end{aligned} \quad (11)$$

where $\eta_l = \min(\min_i((Q_{l,\max} - Q_{l,i})/P_{l,i}), 1)$ denotes the upper bound of τ_l , preventing the battery overflow.

4. Dynamic Resource Allocation Algorithm

In this section, we present a dynamic resource allocation to make a near throughput optimization for the problem formulated in the former section, including DL beamformer design and allocation of WIT energy and duration.

As the optimization problem is formulated, we can divide it into two parts, one of which is the optimal beamformer designing of DL WET for fairness and the other is the optimal time and power allocation of UL WIT for throughput, since we employ the ZF based receive beamforming in the normal information BS proposed by [12], which is not related to ω_l and τ_l .

4.1. Design of WET Beamforming and Computation of EH Probability. Considering fairness of the received power, we determine an optimal beamformer design to maximize the minimum received power for different MUs. To maximize the received power at U_i , we can set $x_{l_0}^2 = P_{\max}$. Generally, the received power for U_i is denoted by

$$P_{l,i}(\omega_l) = P_{\max} \omega_l^H H_{l,i} \omega_l, \quad (12)$$

where $H_{l,i} = h_{l,i} h_{l,i}^H$. Then problem on fairness could be formulated as

$$\begin{aligned} \max_{\omega_l} \min_{1 \leq l \leq K} & P_{l,i} \\ & \|\omega_l\|^2 = 1. \end{aligned} \quad (13)$$

It is easy to relax the max.-min. process by introducing a slack variable \bar{P}_l , and then problem (13) can be transformed into the following:

$$\begin{aligned} \max_{\omega_l} & \bar{P}_l \\ \text{s.t.} & P_{l,i}(\omega_l) \geq \bar{P}_l \quad \forall 1 \leq i \leq K \\ & \|\omega_l\|^2 = 1. \end{aligned} \quad (14)$$

Since the problem is convex, we can follow the approach of convex theory in [28] and consider its Lagrangian function is given by

$$L(\lambda, \omega_l) = -\sum_{i=1}^K \lambda_i (P_{l,i}(\omega_l) - \bar{P}_l), \quad (15)$$

where $\lambda = [\lambda_1, \lambda_2, \dots, \lambda_K] \geq 0$ consists of Lagrange multipliers associated with received power constraints of MUs in problem (14).

The dual function of problem (14) is then given by

$$G(\lambda) = \min_{\omega_l} L(\lambda, \omega_l). \quad (16)$$

The following rule can be used to determine whether problem (14) is feasible. For given $\bar{P}_l > 0$, problem (14) is infeasible in the following interpretation if and only if there exists any $\lambda \geq 0$ such that $G(\lambda) > 0$.

Next, for given $\lambda \geq 0$, we would obtain $G(\lambda)$ by the problem

$$\begin{aligned} \max_{\omega_l} & \sum_{i=1}^K \lambda_i P_{l,i}(\omega_l) \\ & \|\omega_l\|^2 = 1. \end{aligned} \quad (17)$$

With (12), the problem could be transformed as

$$\begin{aligned} \max_{\omega_l} & P_{\max} \omega_l^H A_l \omega_l \\ & \|\omega_l\|^2 = 1, \end{aligned} \quad (18)$$

where $A_l = \sum_{i=1}^K \lambda_i H_{l,i}$.

Since A is a symmetric matrix, the optimal beamformer ω_l^* could be obtained by the result of quadratic problem.

After obtaining ω_l^* for given \bar{P}_l and λ , we can compute the corresponding $P_{l,i}(\omega_l^*)$ and $G(\lambda)$ in (15). If $G(\lambda^*) \leq 0$, it indicates that problem (14) is infeasible. Therefore, we should decrease \bar{P}_l and solve the feasibility problem in (14) again. On the other hand, if $G(\lambda^*) \leq 0$, we can update λ using ellipsoid method until λ converges to λ^* , which denotes the maximizer of $G(\lambda)$ or the optimal dual solution for problem (14). If $G(\lambda^*) \leq 0$, it indicates that the problem is feasible. Then, we should increase \bar{P}_l and solve the feasibility problem again. Finally, \bar{P}_l^* could be obtained numerically by iteratively updating \bar{P}_l by a simple bisection search. Meanwhile, the corresponding ω_l^* should be the optimal beamformer. Finally,

```

(1) set a large number  $N$  and  $\text{suc\_time} = 0$ , where  $\text{suc\_time} \in R^K$ ;
(2) loop
(3) set  $P_{\text{down}} = 0$ ,  $P_{\text{up}} > \bar{P}_i^*$ , generate a stochastic Rayleigh channel  $H_i = [h_{i,1}, \dots, h_{i,K}]$ ,  $n = 0$ ;
(4) loop
(5)  $\bar{P}_i = \frac{1}{2} (P_{\text{down}} + P_{\text{up}})$ ;
(6) set  $\lambda^2 \geq 0$ ;
(7) Given  $\lambda$ , obtain the optimal  $\omega_i$  by quadratic problem;
(8) Computing  $G(\lambda)$  using (15);
(9) if  $G(\lambda) > 0$ ,  $\bar{P}$  is infeasible then
(10) set  $P_{\text{up}} \leftarrow \bar{P}_i$ , go to step (5);
(11) else
(12) update  $\lambda$  using ellipsoid method;
(13) if the stopping criteria of the ellipsoid method is not met then
(14) go to step (7);
(15) end if
(16) end if
(17) set  $P_{\text{down}} \leftarrow \bar{P}_i$ ;
(18) if  $P_{\text{up}} - P_{\text{down}} < \delta$ , where  $\delta > 0$  is a given error tolerance then
(19)  $n = n + 1$ ;
(20) break;
(21) end if
(22) end loop
(23) if  $n = N$  then
(24) obtain energy harvesting probability  $p_i = \text{suc\_time}(i)/N$ ;
(25) break;
(26) end if
(27) end loop

```

ALGORITHM 1: Optimal beamformer and EH probability obtaining algorithm.

we can compute the received power for each MU and determine whether they could harvest the energy, which can be successful only if $P_{i,j} \geq \alpha_j$.

To obtain the EH probability, we can iterate the above steps for N times, where N should be a large number and a different transmitting channel is generated under the rule of Rayleigh distribution for each time. The probability of U_i can be obtained by the ratio of successful harvested times and N , which is denoted by

$$p_i = \lim_{N \rightarrow \infty} \frac{\text{suc_time}_i}{N}, \quad (19)$$

where suc_time_i is the number of successful iterate times.

To summarize, the algorithm to solve the problem is given in Algorithm 1. Steps 5 to 20 give the solution to obtain an optimal beamformer in case that CSI is available.

4.2. Allocation of WIT Energy and Duration. After obtaining the best WET beamformer, we have to determine an optimal allocation of WIT energy and duration. Considering multiple slots, the optimization of the problem would be approached if we keep the average transmitting energy in each slot. This is because uniformly distributing the energy between energy arrivals maximizes the data rate. As proposed in [29], according to the EH probability p_i , we take a fraction p_i of available energy of U_i to transmit information in UL duration. With this energy allocation, we only need to

compute the optimal UL duration in each slot and can obtain a global optimization with multiple slots.

In the case of the system model, the total throughput of U_i in each slot is denoted by

$$R_{i,i}(\tau) = (1 - \tau_i) \log \left(1 + \frac{\tilde{h}_{i,i} p_i (Q_{i,i} + \tau P_{i,i})}{(1 - \tau_i) \sigma^2} \right), \quad (20)$$

where $\tilde{h}_{i,i}$, p_i , $Q_{i,i}$, and $P_{i,i}$ are considered as constant since they are calculated out before duration allocation.

Like the method proposed in Section 4.1, the optimization problem can also be formulated as

$$\begin{aligned}
& \max \quad \bar{R} \\
& \text{s.t.} \quad R_{i,i}(\tau) \geq \bar{R} \quad \forall 1 \leq i \leq K \\
& \quad \quad 0 \leq \tau_i \leq \eta_i,
\end{aligned} \quad (21)$$

where $\eta_i = \min(\min_i((Q_{i,\max} - Q_{i,i})/P_{i,i}), 1)$ denotes the upper bound of τ_i , preventing the battery from overflow.

Since the problem is convex, we can also solve the problem by the Lagrangian method, which is proposed in Section 4.1. What is different between two problems is how to obtain $\max_{\tau_i} \sum_{i=1}^K \lambda_i R_{i,i}(\tau_i)$.

```

(1) set  $R_{\min} = 0, R_{\max} > \bar{R}^*$ ;
(2) loop
(3)  $\bar{R} = \frac{1}{2} (R_{\min} + R_{\max})$ ;
(4) set  $\lambda^2 \geq 0$ ;
(5) Given  $\lambda$ , obtain the optimal  $\tau_i$  according to the golden section search method;
(6) Computing  $G(\lambda)$ ;
(7) if  $G(\lambda) > 0$  then
(8)    $\bar{R}$  is infeasible, set  $R_{\max} \leftarrow \bar{R}$ , go to step (3);
(9) else
(10)  update  $\lambda$  using ellipsoid method;
(11)  if the stopping criteria of the ellipsoid method is not met then
(12)    go to step (5)
(13)  end if
(14) end if
(15) set  $R_{\min} \leftarrow \bar{R}$ ;
(16) if  $R_{\max} - R_{\min} < \delta$ , where  $\delta > 0$  is a given error tolerance then
(17)   The corresponding  $\tau_i$  is the optimal duration;
(18)   break;
(19) end if
(20) end loop

```

ALGORITHM 2: Optimal time allocation algorithm.

Since (20) is concave, with $\lambda > 0$, we can easily find that the following function is also concave:

$$f(\tau_i) = \sum_{i=1}^K \lambda_i R_{i,i}(\tau_i). \quad (22)$$

Consequently, one-dimensional search methods are considered to help us obtain the optimal τ_i .

The algorithm to solve the problem is given in Algorithm 2.

5. Performance Results and Analysis

In this section, we focus on algorithm simulations and comparative analyses among algorithms by using MATLAB simulation tool. Moreover, we analyze simulation results based on the main problems which we have discussed in previous sections, including fairness, sensitivity, and throughput performance.

5.1. Parameter Settings. In this section, several simulations are executed to testify the performance of the proposed algorithm in three aspects of fairness, sensitivity, and max.-min. throughput. We make some comparison between the fair allocation algorithm of using fraction p of energy (UFPE) and the algorithm in [12], where MUs would use all the energy stored in their battery (UAE). Before the simulations, the following settings are used unless stated otherwise, as shown in Table 1.

5.2. Simulation Result and Analysis

5.2.1. Fairness. While each MU is allocated the same slot to transmit information uplink leading to the fact that the

TABLE 1: Simulation parameters.

Parameters	Value
BS antennas number, M	3
MU number, K	2
Propagation constant, α_0	1
Path loss exponent, β	2
Shadow fading, C_i	1
Propagation distance, D_1	10 m
Propagation distance, D_2	5 m
P_{\max}	1 W
Channel noise power, σ^2	10^{-7} W
Battery max capacity, Q_{\max}	0.005 J
Power sensitivity of EH circuits, α_1	0.03 W
Power sensitivity of EH circuits, α_2	0.05 W

increase or decrease of slot length would lead to the same trend of throughput of each MU, the fairness of the model is mainly reflected on the WET energy beamforming. We compare our algorithm of allocating beamformer by channel in UFPE with the algorithm of allocating beamformer by distance weight in UAE. Since the fairness will be more obvious if received power difference among MUs is smaller, we can obtain the standard deviation of received power among all MUs. For simplicity, assuming that there are only two MUs, we can compute the results difference between two MUs rather than the standard deviation of them.

Figure 4 shows the received power difference between two MUs versus the distance between U_2 and the virtual eBS. It is easy to see that both curves achieve the minimum when the distance is around 10 m and increase as the distance increases or decreases from this value. It is because of the fact that

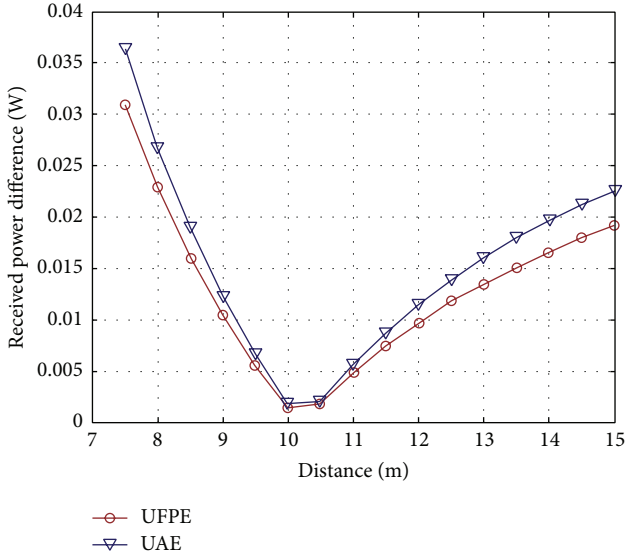

FIGURE 4: Received power difference between two MUs versus the distance between U_2 and virtual energy BS.

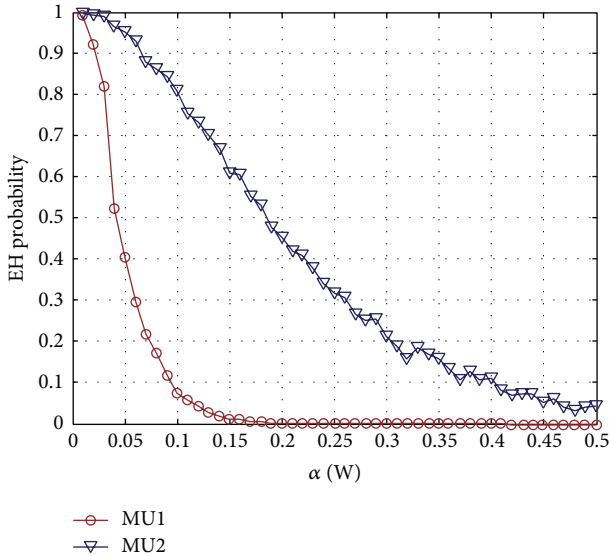

FIGURE 5: EH probability of two MUs versus circuit sensitivity.

the distance between U_1 and BS is fixed to 10 m in this scenario; the factors influencing both channels would be much similar when the distance of U_2 fluctuates around this value. We can also see that our algorithm UFPE shows a lower difference compared with UAE, indicating that fairness of our model is more highlighted.

5.2.2. Sensitivity. Since the sensitivity of circuit of receiver exits, MUs may not always harvest the energy they received. The energy harvesting probability of two MUs versus different circuit sensitivity is shown in Figure 5. It is easy to see that the energy harvesting probabilities of MU1 and MU2 decrease with the circuit sensitivity since it will become more difficult for the receiver to harvest energy when the circuit sensitivity

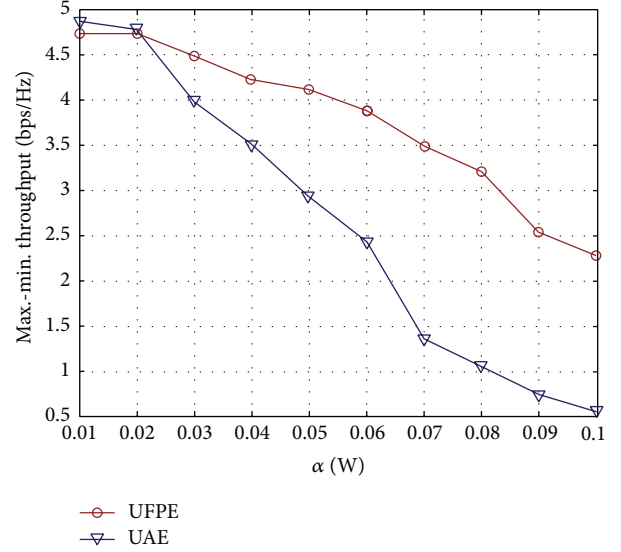

FIGURE 6: Maximum-minimum throughput between two MUs versus circuit sensitivity.

is much too high. What is more, U_2 shows a higher probability than U_1 at the same α since the distance between U_2 and virtual eBS is shorter, causing more power to be received than U_1 . Since U_1 's channel is worse, its EH probability decreases rapidly when α is not too big.

5.2.3. Throughput Performance. On the WIT phase, we aim to maximize the minimum throughput among MUs by obtaining an optimal power and time allocation. This subsection can be divided into two parts, one is for power allocation and the other is for time allocation.

(a) Power Allocation. In this part, we compare our algorithm UFPE, in which the power allocation is using fraction p of energy, with UAE, in which the power allocation is using up all the battery energy. The max.-min. throughput among MUs versus circuit sensitivity can be seen in Figure 6, which indicates that the max.-min. throughput of both algorithms decreases as the sensitivity grows. Moreover, UFPE shows a higher throughput than UAE when α is larger than 0.02 W, and the difference will enlarge as α grows. The throughput of UFPE is about 3.3 times of that of UAE when α achieves 0.09 W. This means that our algorithm performs better in the practical scenario where circuit sensitivity exists.

Figure 7 depicts the max.-min. throughput among MUs versus Q_{\max} . It can be seen that the max.-min. throughput of both algorithms increases as Q_{\max} grows. It is because of the fact that as Q_{\max} grows, the constraints of battery would be more relaxed, which can help MUs allocate a more adaptive slot to transmit information. On the other hand, both curves increase more smoothly when Q_{\max} is higher, since the energy harvested at MUs will be more difficult to make the battery fully charged, causing the battery constraint to work no more. What is more, UFPE also shows a better performance than UAE with each specific Q_{\max} .

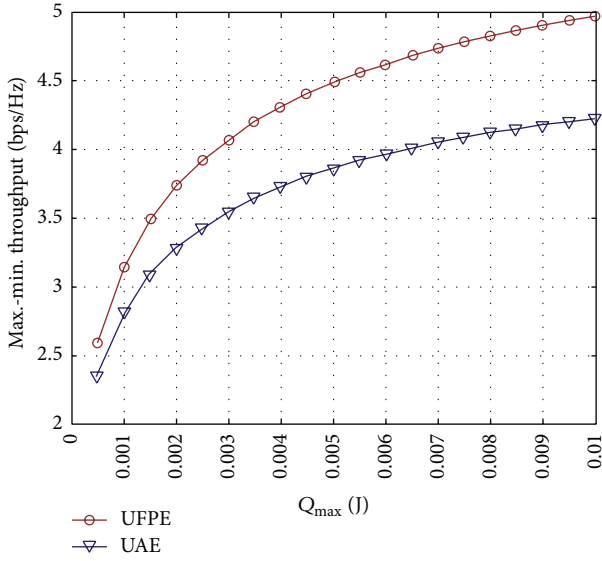

FIGURE 7: Maximum-minimum throughput between two MUs versus Q_{max} .

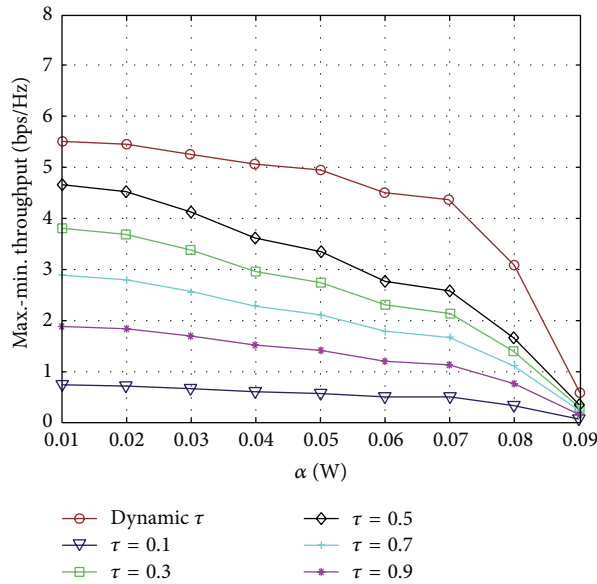

FIGURE 8: Maximum-minimum throughput versus circuit sensitivity with different τ .

(b) *Slot Allocation.* An optimal slot allocation is also necessary to obtain better throughput performance. Figure 8 shows the comparison of our algorithm (dynamically allocating τ in each slot) and other models, where the slot τ is fixed to several values during every period. Generally, we choose five values with $\tau = 0.1, 0.3, 0.5, 0.7, 0.9$, respectively. It can be seen that the algorithm of dynamic allocating τ shows better performance than any other algorithm with fixed τ . The model of $\tau = 0.5$ performs better than any other model of fixed τ . On the contrary, the model of $\tau = 0.1$ shows the worst performance.

6. Conclusion

In this paper, we have studied a DEIN model based on virtualization, with a multiantenna virtual eBS, a multi-antenna dBS, and K single-antenna MUs with finite battery capacity. We proposed a fair resource allocation algorithm by joint optimization of the DL-UL time allocation, DL energy beamforming, and UL transmit power allocation with ZF based receive beamforming. Considering fairness, we firstly design the DL energy beamforming to maximize the minimum received power. After calculating the probability of energy being transmitted from the virtual eBS to MUs, we propose a simple power allocation with a fraction p of available energy allocated for UL WIT and adaptive time allocation in each slot. The simulation results have shown that the proposed UFPE algorithm achieves good performance.

Conflict of Interests

The authors declare that there is no conflict of interests regarding the publication of this paper.

Acknowledgment

This work is partly supported by the Experts Recruitment and Training Program of 985 Project (no. A1098531023601064).

References

- [1] M. Chiosi, D. Clarke, P. Willis et al., "Network functions virtualization: an introduction, benefits, enablers, challenges and call for action," in *Proceedings of the SDN and OpenFlow World Congress*, pp. 22–24, Darmstadt, Germany, October 2012.
- [2] K. Doyle, *Is Network Function Virtualization (NFV) Moving Closer to Reality?* Global Knowledge Training LLC, 2014.
- [3] E. Hernandez-Valencia, S. Izzo, and B. Polonsky, "How will NFV/SDN transform service provider opex?" *IEEE Network*, vol. 29, no. 3, pp. 60–67, 2015.
- [4] J. A. Paradiso and T. Starner, "Energy scavenging for mobile and wireless electronics," *IEEE Pervasive Computing*, vol. 4, no. 1, pp. 18–27, 2005.
- [5] S. Ulukus, A. Yener, E. Erkip et al., "Energy harvesting wireless communications: a review of recent advances," *IEEE Journal on Selected Areas in Communications*, vol. 33, no. 3, pp. 360–381, 2015.
- [6] A. Dolgov, R. Zane, and Z. Popovic, "Power management system for online low power RF energy harvesting optimization," *IEEE Transactions on Circuits and Systems. I. Regular Papers*, vol. 57, no. 7, pp. 1802–1811, 2010.
- [7] X. Lu, P. Wang, D. Niyato, D. I. Kim, and Z. Han, "Wireless networks with RF energy harvesting: a contemporary survey," *IEEE Communications Surveys & Tutorials*, vol. 17, no. 2, pp. 757–789, 2015.
- [8] H. Liu, X. Li, R. Vaddi, K. Ma, S. Datta, and V. Narayanan, "Tunnel FET RF rectifier design for energy harvesting applications," *IEEE Journal on Emerging and Selected Topics in Circuits & Systems*, vol. 4, no. 4, pp. 400–411, 2014.
- [9] J. Yang and S. Ulukus, "Optimal packet scheduling in an energy harvesting communication system," *IEEE Transactions on Communications*, vol. 60, no. 1, pp. 220–230, 2012.

- [10] O. Ozel, K. Tutuncuoglu, J. Yang, S. Ulukus, and A. Yener, "Transmission with energy harvesting nodes in fading wireless channels: optimal policies," *IEEE Journal on Selected Areas in Communications*, vol. 29, no. 8, pp. 1732–1743, 2011.
- [11] K. Tutuncuoglu and A. Yener, "Optimum transmission policies for battery limited energy harvesting nodes," *IEEE Transactions on Wireless Communications*, vol. 11, no. 3, pp. 1180–1189, 2012.
- [12] L. Liu, R. Zhang, and K. C. Chua, "Multi-antenna wireless powered communication with energy beamforming," *IEEE Transactions on Communications*, vol. 62, no. 12, pp. 4349–4361, 2014.
- [13] Z. Zhou, M. Dong, K. Ota, and Z. Chang, "Energy-efficient context-aware matching for resource allocation in ultra-dense small cells," *IEEE Access*, vol. 3, pp. 1849–1860, 2015.
- [14] Y. L. Wu, G. Min, and A. Y. Al-Dubai, "A new analytical model for multi-hop cognitive radio networks," *IEEE Transactions on Wireless Communications*, vol. 11, no. 5, pp. 1643–1648, 2012.
- [15] L. R. Varshney, "Transporting information and energy simultaneously," in *Proceedings of the IEEE International Symposium on Information Theory (ISIT '08)*, pp. 1612–1616, Toronto, Canada, July 2008.
- [16] P. Grover and A. Sahai, "Shannon meets tesla: wireless information and power transfer," in *Proceedings of the IEEE International Symposium on Information Theory (ISIT '10)*, pp. 2363–2367, IEEE, Austin, Tex, USA, June 2010.
- [17] K. Huang and E. Larsson, "Simultaneous information and power transfer for broadband wireless systems," *IEEE Transactions on Signal Processing*, vol. 61, no. 23, pp. 5972–5986, 2013.
- [18] D. W. K. Ng, E. S. Lo, and R. Schober, "Wireless information and power transfer: energy efficiency optimization in OFDMA systems," *IEEE Transactions on Wireless Communications*, vol. 12, no. 12, pp. 6352–6370, 2013.
- [19] A. M. Fouladgar and O. Simeone, "On the transfer of information and energy in multi-user systems," *IEEE Communications Letters*, vol. 16, no. 11, pp. 1733–1736, 2012.
- [20] A. A. Nasir, X. Zhou, S. Durrani, and R. A. Kennedy, "Relaying protocols for wireless energy harvesting and information processing," *IEEE Transactions on Wireless Communications*, vol. 12, no. 7, pp. 3622–3636, 2013.
- [21] C. Shen, W.-C. Li, and T.-H. Chang, "Simultaneous information and energy transfer: a two-user MISO interference channel case," in *Proceedings of the IEEE Global Communications Conference (GLOBECOM '12)*, pp. 3862–3867, Anaheim, Calif, USA, December 2012.
- [22] J. Park and B. Clerckx, "Joint wireless information and energy transfer in a two-user MIMO interference channel," *IEEE Transactions on Wireless Communications*, vol. 12, no. 8, pp. 4210–4221, 2013.
- [23] X. M. Chen, X. M. Wang, and X. F. Chen, "Energy-efficient optimization for wireless information and power transfer in large-scale MIMO systems employing energy beamforming," *IEEE Wireless Communications Letters*, vol. 2, no. 6, pp. 667–670, 2013.
- [24] H. Ju and R. Zhang, "Throughput maximization in wireless powered communication networks," *IEEE Transactions on Wireless Communications*, vol. 13, no. 1, pp. 418–428, 2014.
- [25] G. Yang, C. K. Ho, R. Zhang, and Y. L. Guan, "Throughput optimization for massive MIMO systems powered by wireless energy transfer," *IEEE Journal on Selected Areas in Communications*, vol. 33, no. 8, pp. 1640–1650, 2015.
- [26] I. Ahmed, A. Ikhlef, D. W. K. Ng, and R. Schober, "Power allocation for an energy harvesting transmitter with hybrid energy sources," *IEEE Transactions on Wireless Communications*, vol. 12, no. 12, pp. 6255–6267, 2013.
- [27] J. Xu, L. Liu, and R. Zhang, "Multiuser MISO beamforming for simultaneous wireless information and power transfer," in *Proceedings of the IEEE International Conference on Acoustics, Speech and Signal Processing (ICASSP '13)*, pp. 4754–4758, Vancouver, Canada, May 2013.
- [28] S. Boyd and L. Vandenberghe, *Convex Optimization*, Cambridge University Press, Cambridge, UK, 2004.
- [29] K. Liang, L. Q. Zhao, K. Yang, G. Zheng, and W. Ding, "A fair power splitting algorithm for simultaneous wireless information and energy transfer in comp downlink transmission," *Wireless Personal Communications*, vol. 85, no. 4, pp. 2687–2710, 2015.

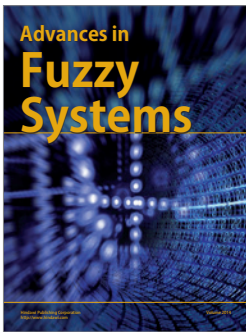
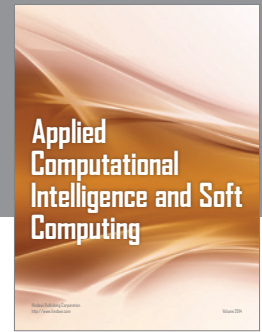
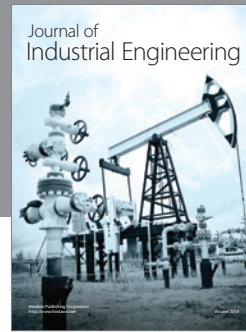
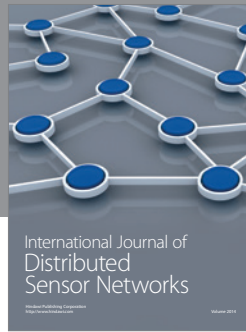
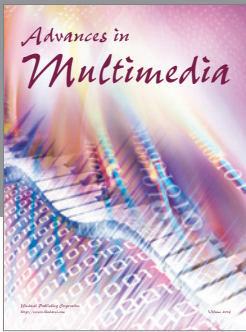

Hindawi

Submit your manuscripts at
<http://www.hindawi.com>

