

Analog Radio-over-Fiber Supported Increased RAU Spacing for 60GHz Distributed MIMO employing Spatial Diversity and Multiplexing

Usman Habib, *Student Member, IEEE* Anthony E. Aighobahi, *Member, IEEE*, Terence Quinlan, Stuart D. Walker and Nathan J. Gomes, *Senior Member, IEEE*

Abstract The improvements in coverage through spatial diversity and increased data rates through spatial multiplexing using a distributed Multiple-Input Multiple-Output (MIMO) system are important targets for future wireless communications. Here, the appropriate separation of Remote Antenna Units (RAUs) at several user locations in a millimeter-wave system is demonstrated. An analog Radio over Fiber (RoF) fronthaul is used to achieve flexible spacing of distributed RAUs and transports two Gb/s data streams over 2.2km of fiber and up to 8m of 60 GHz wireless transmission distance. A performance comparison is performed between Single-Input Single-Output (SISO) and MIMO operation using different antenna spacing and transmission distance. Results show that the wider RAU spacing enabled by the RoF distribution provides improved results at longer distances, for both spatial diversity and for spatial multiplexing. Verification of a method for measuring each channel coefficient individually and using subsequent MIMO processing on these coefficients, enables an extension to the results showing the feasibility of 30m indoor transmission.

Index Terms—Radio-over-Fiber (RoF), Millimeter Wave (mmW), Multiple-input Multiple-output (MIMO)

I. INTRODUCTION

The advancements in mobile communications and demands for higher data rates has led to increased interest in the use of millimeter-wave (mmW) frequencies due to the large available bandwidth, especially in the unlicensed band around 57 – 66 GHz, and in the likely future 5G band extending up to 71GHz [1], [2]. However, there are associated technical challenges, such as: (1) high path loss which, even in Line-of-Sight (LOS) scenarios, limits coverage distances; (2) the need for an ultra-high capacity fronthaul or fiber distribution network in cases where Centralized-Radio Access Network (C-RAN) or distributed antenna system (DAS) deployments are favored [3]; and (3) the more costly, and generally less capable, integrated hardware compared to lower frequencies [4].

Multiple-input multiple-output (MIMO) techniques provide enhanced coverage through spatial diversity, and high aggregate data rates through spatial multiplexing, as compared to single-input single-output (SISO) transmission [5], [6]. Spatial diversity can be achieved using Alamouti Space-Time Block Coding (STBC) which is a prominent transmit diversity technique using a set of orthogonal codes for the transmission, with the received signals then combined coherently to provide

an improvement in the performance [7]. Multiplexing gain through MIMO is achieved when individual data streams are combined in moderate SNR conditions, where transmission of a single higher data-rate data signal over large bandwidth is not possible [8]. In a system with distributed radio units, the MIMO processing of the distributed wireless signals is referred to as Co-ordinated Multipoint (CoMP) transmission, which has been demonstrated in systems using Radio-over-Fiber (RoF) links at lower frequencies [9]. At mmW frequencies, it has been shown that MIMO gain can be achieved in LOS operation [10]. Recently, a few groups have demonstrated 60GHz LOS MIMO with single RAU operation [11-13] and CoMP using a two RAU configuration [14]. But the analysis on Distributed MIMO (or CoMP) transmission to exploit *spatial diversity* and *spatial multiplexing at multiple user locations* remains to be performed, to understand the performance enhancement in terms of coverage and data rate improvements that may be gained from such systems. The deployment of such mmW distributed MIMO systems will require RAUs to be placed at appropriate distances in order to provide coverage at various user locations, and high bit-rate services. RoF transport provides a robust, low loss, and flexible means for deploying the fronthaul connecting the RAUs to a centralized unit [15, 16], enabling the more widely spaced RAUs.

For example, Fig. 1 shows a mmW transmission system where N RAUs are connected to a Central Unit (CU) through a RoF fronthaul, as might be expected in shopping malls, outdoor downtown areas, etc. A user is served with a Gb/s mmW link from a single RAU (RAU1) with a limited coverage region through a directed beam. When the user moves, the SNR, and hence performance, degrades considerably at the boundaries of the coverage region. The degradation of performance can even result in loss of link connection at the edges of the RAU's coverage span (as with RAU2). Coordinated transmission from two RAUs (RAU3 and RAU4) can provide a solution in this case, resulting in enhancement of performance and link quality through STBC encoded data streams (transmitting symbols S_1, S_2 over the first symbol period and complex conjugate symbols $-S_2^*, S_1^*$ over the second symbol duration). For spatial multiplexing, in cases where moderate SNR is available from more than one RAU, multiple Gb/s data streams can be combined to obtain very high aggregate data rate. The integration of RoF transport and mmW MIMO is a promising solution to transport large bandwidth signals from the CU.

In this paper, a complete system combining RoF transport, integrated mmW components and 60GHz MIMO is presented, with experimental demonstration of improvement using Alamouti STBC and Zero-Forcing (ZF) algorithms. Also, for

¹Manuscript received January 30, 2018. This work was supported by the projects RAPID, iCIRRUS and NIRVANA.

U. Habib, A. E. Aighobahi and N. J. Gomes are with the Communication Research Group, University of Kent, Canterbury UK (uh23@kent.ac.uk).

T. Quinlan, S. D. Walker are with the Access Networks Group, School of Computer Science and Electronic Engineering, University of Essex, UK.

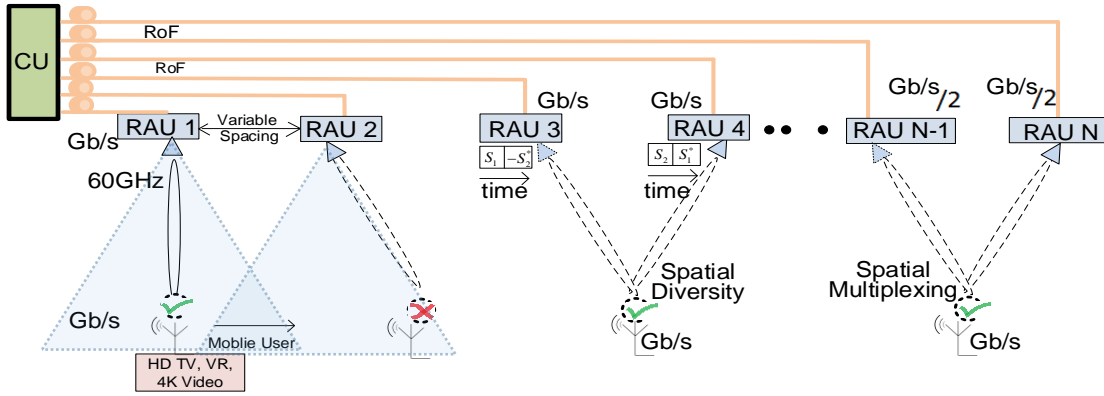

Fig. 1. Coordinated access scenario through multiple RAUs at mmW for Mobile User

the Orthogonal Frequency Division Multiplexing OFDM-RoF transported system, the effect of transmit antenna separation (enabled by the separated RAUs) and the extent of the improvement achieved through mmW MIMO compared to SISO is investigated. This work extends our previous realization of 2x2 MIMO where performance projections were made using measurements from a single transmit antenna [17] and were validated for 1.5m wireless distance through real MIMO [18]. Here we present the first demonstration of mmW MIMO exploiting spatial diversity *and* spatial multiplexing at wireless distances of the order of what might be expected in real, future mm-wave systems (up to 8m), with projections to much longer distances (up to 30m) using further validation of single antenna measurements. The experimental arrangement is explained in Section II while results for the two MIMO algorithms applied to different RAU spacings and user positions are discussed in Section III. In Section IV, the processing using individual channel coefficient measurements and comparison with 2x2 MIMO is described. Conclusions follow in Section V.

II. EXPERIMENTAL METHODOLOGY

A. Experimental Setup for RoF-OFDM based 60GHz Distributed MIMO transmission

Fig. 2 shows the experimental setup where two 16-Quadrature Amplitude Modulation (QAM) OFDM signals at an IF of 1.5GHz are generated from separate channels of a Tektronix 7122C Arbitrary Waveform Generator (AWG). The OFDM (IFFT size of 512, Cyclic Prefix 1/8, 16-QAM modulation) baseband symbols were generated in MATLAB/Simulink and uploaded to the AWG which creates the IF waveform signals. These directly modulate a pair of similar Emcore 1935F Distributed Feedback (DFB) laser diodes having 3dBm output optical power. The input drive power level to the DFB of each data modulated IF signal was set to 0dBm to avoid significant laser nonlinear effects.

The optical signals were each transmitted over 2.2 km length single mode fibers (SMF) from the CU to the RAUs. Each RAU includes a 2.5GHz bandwidth photodiode to retrieve the data modulated IF signal. A 21dB gain RF amplifier is used to compensate for the loss of the RoF link. The IF signal is upconverted to mmW frequency using an integrated transmitter (Gotmic gTSC0020) after being passed through a differential

balun and DC blocker (8.5dB loss). The integrated transmitter gTSC0020 includes an upconverter, which converts the IF signal to a 61.5GHz signal, and an amplifier. It also includes a x6 multiplier which means it is driven at around 10 GHz, with an LO power of 10dBm. The 61.5 GHz data modulated signal is transmitted using a 20dBi gain V-band horn antenna. At the receiver end, a wideband, distributed-slot antenna with 15dBi gain is used [19]. The developed pluggable antenna, shown in Fig. 2 (right), is a low-cost, small size design and has a quasi-discoidal radiation pattern which permits reception from a wide range of angles compared to the horn antennas. The received signal is amplified by a V-band amplifier with 30dB gain and is downconverted to IF using a (Gotmic gRSC0016) integrated receiver, which also requires an LO power of 10dBm at 10 GHz. The IF signal at 1.5GHz is amplified by the integrated receiver and is then passed through DC blockers, RF Balun and amplified by a 15dB gain broadband amplifier. The output of this IF amplifier is captured using a Tektronix Digital Oscilloscope DPO72304DX for offline processing. The offline processing includes manual time alignment using a MATLAB script, carrier synchronization and channel estimation. OFDM preambles (which are known to both transmitter and receiver) transmitted with the data symbols are used to perform Least Square (LS) estimation. The singular values of the channel matrix H for the two MIMO channels are obtained from the Singular Value Decomposition (SVD) and are used for MIMO processing using the STBC or ZF algorithms.

QAM demodulation for EVM analysis.

B. Geometrical Arrangement of RAUs for Measurements using Spatial Diversity and Spatial Multiplexing

To perform the analysis of the coverage of the 60GHz transmission system, seven user locations for the receiver were selected over a span of 2.5m as shown in Fig. 3. At the location M, which is the mid-point on the span, the receiver is at 0° with respect to the normal from the SISO transmitter. To evaluate the improvement in performance through MIMO, SISO transmission measurements were performed as a baseline.

The SISO measurements were taken by capturing the data at each user location by pointing the horn antenna (placed on a small tripod) towards the receiver unit. MIMO experiments were performed by tilting the two transmit antennas towards the user locations to ensure the reception of a LOS component. The

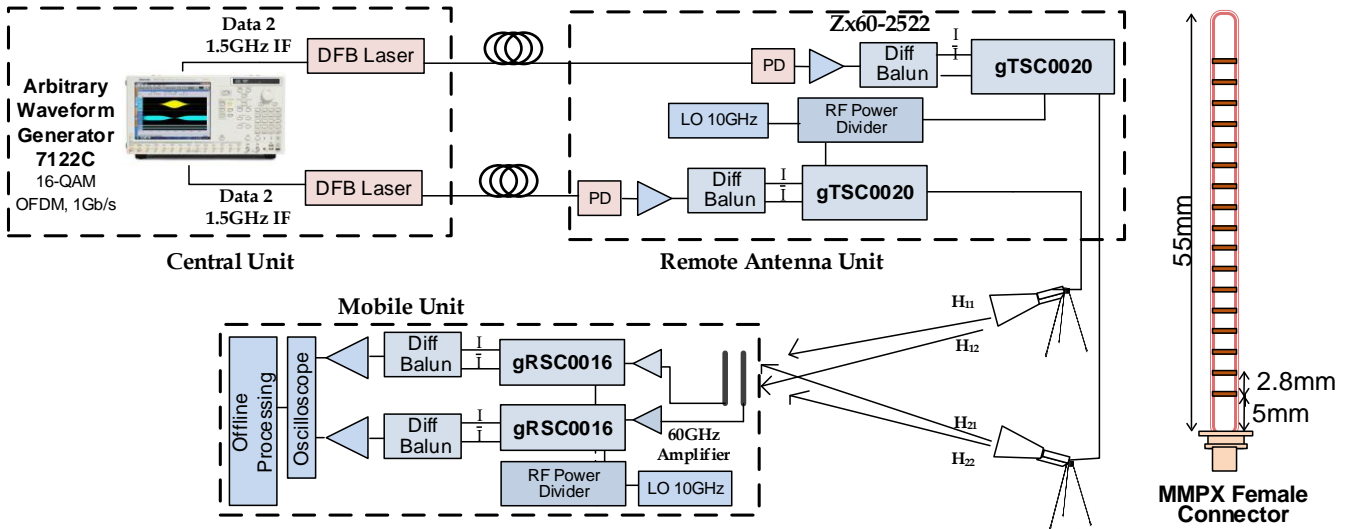

Fig 2. System architecture for the RoF transported 60GHz Distributed MIMO transmission (left) 15dBi Gain Quasi-discooidal slot-array antenna (right)

total transmit power was kept the same for SISO and MIMO. The EVM limit of 12.5% for Long-Term Evolution (LTE) standard for 16-QAM is used to benchmark performance. Although this requirement is for the transmitter, it has been considered here for the end-to-end system, for example, to allow for the addition of a Power Amplifier (PA) which is often a significant contributor to distortion. For MIMO, different separations of 30cm, 60cm, 90cm and 120cm experiments were performed for transmission distances of 5m, 6m, 7m and 8m.

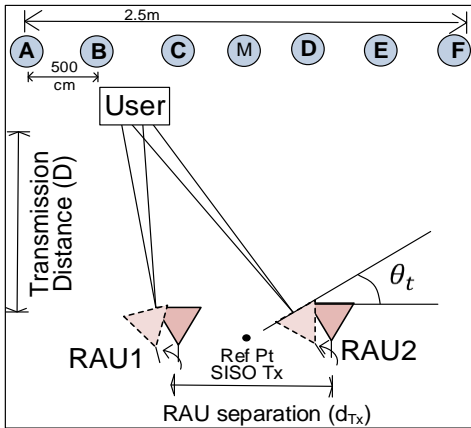

Fig 3. Geometrical Orientation of the Antennas and User Locations

III. DISTRIBUTED MIMO PERFORMANCE AND EFFECT OF TRANSMIT ANTENNA SPACING

The results for MIMO transmission show the performance improvement through spatial diversity and spatial multiplexing using the STBC and Zero Forcing receiver, respectively. Fig. 4 shows the achieved improvement in EVM through spatial diversity using Alamouti STBC compared to SISO, for the transmission distances of 6m (an intermediate distance during the experiment) and 8m (the longest distance considered for this experiment). For 6m transmission with transmit antenna spacing of 60cm, an improvement in coverage can be observed through using Alamouti STBC coding, as EVM below the 12.5% limit is achieved for the user locations at the boundaries of the coverage area (locations A,B,D and F) where SISO performance was above this EVM limit. The improvement in coverage is more obvious from MIMO results at 8m

transmission with 120cm of transmit antenna separation. Experiments were performed with different RAU separation which will be discussed in the following paragraphs. The best RAU separation which gave the minimum set of EVM has been selected, to show the MIMO results, in Fig. 4 to compare with SISO.

The analysis for spatial multiplexing is presented in Fig. 5. This shows that SISO transmission at 0.5Gb/s and the MIMO transmission with a multiplexed data rate of 1Gb/s (for optimal RAU separation) both have EVM values below the 12.5% limit after 6m and 8m wireless transmission. The transmitter separation distance was maintained at 60cm for 6m transmission and 120cm for 8m transmission distance in the

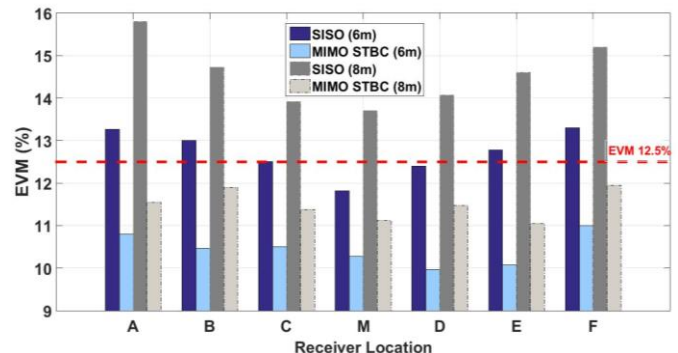

Fig 4. EVM comparison of SISO (1Gb/s) versus STBC MIMO processing (1Gb/s) for 6m (RAU spacing: 60cm) and 8m (RAU spacing: 120cm)

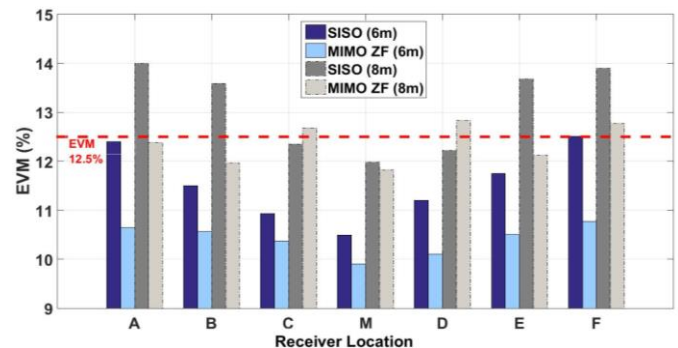

Fig 5. EVM comparison of SISO (0.5Gb/s) versus Zero Forcing MIMO processing (1Gb/s) for 6m (RAU spacing: 60cm) and 8m (RAU spacing: 120cm)

results of Fig. 5, to achieve the best MIMO performance.

To experimentally analyze the effect of transmit antenna separation on the MIMO performance, the experiments were performed for the experimental configuration of 30cm, 60cm, 90cm and 120cm transmit antenna separation for each transmission distance of 5m, 6m, 7m and 8m. The effect of changing the transmit antenna separation for four user locations is shown in Fig. 6 (for simplicity, results for only 6m and 8m are examples), for the transmission distance of 6m. The lowest set shown, as well as only locations on one side of the normal, as of EVM was obtained for the separation distance of 60cm after STBC and ZF processing. As a comparison, the results after 8m transmission are shown in Fig. 7 for STBC and ZF, which shows that overall the best set of EVM was obtained at a larger spacing of 120cm.

Theoretical models for mmW 2x2 MIMO predict that the optimal performance through LOS operation [20] for a wireless transmission distance of D can be achieved by having a transmit antenna separation given by

$$d_{Tx} = D\lambda / 2d_{Rx} \cos(\theta_t) \cos(\theta_r) \quad (1)$$

where λ is the mmW transmission wavelength and d_{Tx} , d_{Rx} are the separation distances between the transmitting and receiving antennas, respectively. θ_t represents the angle of tilt of the transmit antennas in the plane of transmission and θ_r is the tilt of receiving antennas. For 61.5GHz, if θ_t , θ_r are considered to be ideally 0° at the transmitter and receiver side (which is difficult to achieve accurately, experimentally), and keeping d_{Rx} to be constant at 2.1cm (minimum separation that was possible and used in the experiments), the optimal transmit antenna separation for wireless transmission distances according to (1) is shown in Fig. 8. The experimental results have also been shown for the RAU separation giving the lowest set of EVM values (out of the four values of 30, 60, 90 and 120cm) at a particular transmission distance,

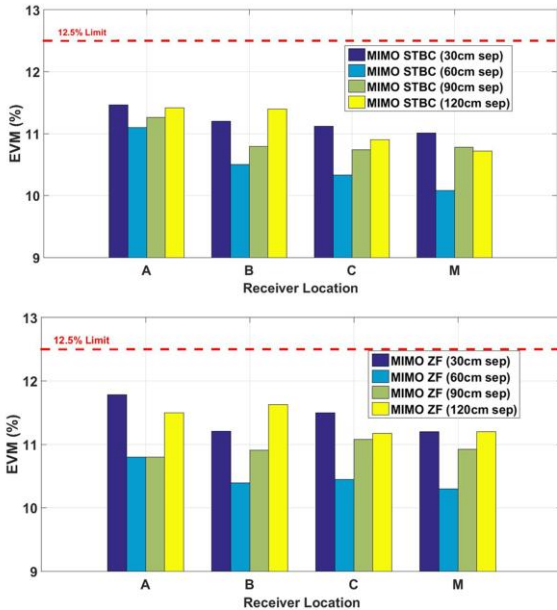

Fig 6. EVM comparison of 2x2 MIMO for various Transmit antenna separation at 6m transmission distance using STBC (upper) and ZF (lower) processing

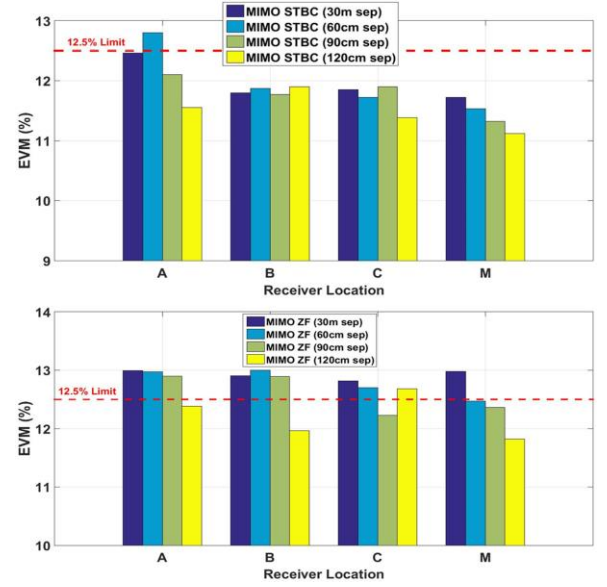

Fig 7. EVM comparison of 2x2 MIMO for various Transmit antenna separation at 8m transmission distance using (upper) STBC (lower) ZF processing

noting that the actual best separation may have been between those set of values which were used. Error bars for the experimental results shows the range of spacing in which the minimum set of EVM values can be obtained. For example, the best experimental MIMO results after 7m wireless transmission were found for the spacing of 90cm, when only four set of spacing were used. The minimum set of EVM can lie between $90\text{cm} \pm 30\text{cm}$ as shown by the error bar. For 8m, what can be determined, again as shown by the error bars, is that the best spacing is greater than 90 cm. Overall, the general trend from the measurement is in agreement with the theoretical prediction using (1).

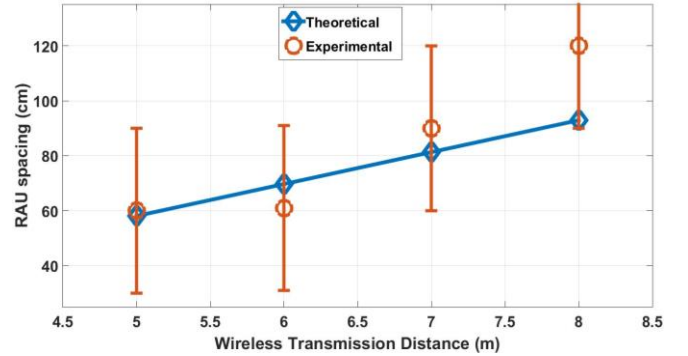

Fig 8. Theoretical Optimum Antenna Spacing for 2x2 MIMO versus Experimental values with error bars to represent the ranges between discrete points at which measurements were taken.

To summarize, the analysis in this section shows that RAU separation has a significant effect on MIMO processing. Using RoF fronthaul with distributed RAUs provides the possibility for increasing the inter-antenna distance (which will generally be required considering the theoretical and experimental values in Fig. 8), in addition to system benefits such as deployment flexibility, centralized access, low loss and low power consumption [11].

IV. MIMO PROCESSING USING SEPARATE CHANNEL COEFFICIENT MEASUREMENTS

The study of the previous section has been limited to 8m wireless distance due to a lack of components in our laboratory; a second 60GHz amplifier, allowing one for each transmitting antenna, would allow measurements to be extended to longer distances. In order to demonstrate the feasibility of the MIMO system in this situation, the approach described in [18] can be followed. The transmitter is placed sequentially at two RAU locations. For each RAU transmitter location, the received signal is captured at two receiving antenna positions (2.1 cm apart), constituting one user location. Through post-processing, the 2×2 channel matrix is obtained [21] although only one RAU (and mm-wave amplifier) is used at any one time. Then, processing using the STBC and ZF algorithms is performed on the captured waveforms. The captured data is processed using the STBC and ZF algorithms.

Fig. 9 shows a good agreement of the results for STBC processing from the emulated approach and real MIMO, for 6m and 8m wireless distances, demonstrating the validity of the approach at different transmission distances. The optimum RAU spacing for MIMO operation also agrees with the previous results. This “emulated MIMO” processing technique can be used to extend the analysis to much longer distances.

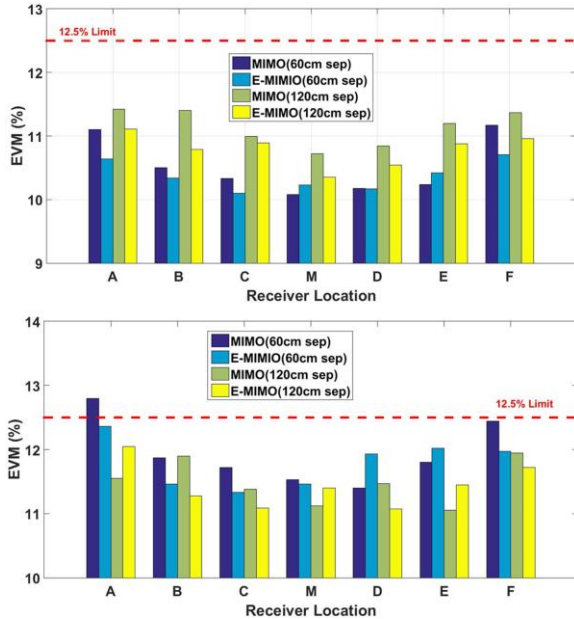

Fig 9. EVM comparison of 2x2 MIMO using STBC processing at 6m (top) and 8m transmission distance (bottom) and equivalent emulated measurements

Figure 10 shows such a scenario in the corridors of our building, where a receiver has LoS access to two RAU positions supported by separate RoF links from the CU. Emulated MIMO is performed by placing the transmit antenna at the positions of RAU1 and RAU2, and capturing the data at the receiver. The results of SISO transmission are compared with STBC and ZF processing in Table 1, showing the feasibility of using MIMO for performance improvement at 25m and 30m. Although close to the requirement, some values after ZF processing are slightly above 12.5%, but these still satisfy the requirement for 16-QAM with Forward Error Correction (FEC) [22].

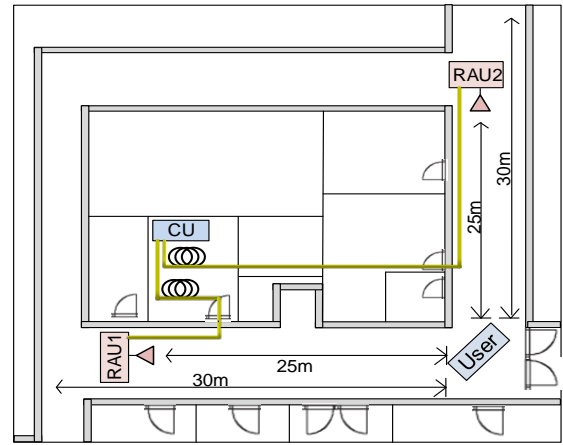

Fig 10. Layout of the Measurement Location

Table 1. SISO versus Emulated MIMO processing results

Distance	SISO (1Gb/s)	STBC (1Gb/s)	SISO (0.5Gb/s)	ZF (1Gb/s)
25m	14.5%	12.1%	12.3%	12.9%
30m	15.1%	12.4%	12.8%	13.3%

V. CONCLUSION

Analog RoF fronthaul has been presented for 60GHz distributed MIMO to achieve flexibility and performance improvement with increased RAU spacing. The RAU spacings at several wireless transmission distances demonstrate improved mmW coverage through spatial diversity and improved data rate through spatial multiplexing. Results at different user locations show that wider transmit antenna separations, more easily obtained through the RoF transport, are required for longer wireless distances. A technique to process measured individual channel coefficients with CoMP/MIMO algorithms has been used to verify that the channels are relatively static and to show the MIMO performance benefits at distances of up to 30m for the 60 GHz wireless transmission. Future work will include projections of MIMO performance to $N \times N$ massive MIMO system in dense user environments, to optimize the number of RAUs and improve mmW coverage.

ACKNOWLEDGMENT

This work has been supported by the European Union’s Horizon 2020 Research and Innovation programme under contract 643297 (RAPID), 644526 (iCIRRUS) and the UK Engineering and Physical Sciences Research Council’s NIRVANA project (Reference No. EP/L026031/1).

REFERENCES

- [1] E.L. Cid, M.P.Taboas, M.G.Sanchez and A.V.Alejos, "Microcellular Radio Channel Characterization at 60 GHz for 5G Communications", *IEEE Antennas and Wireless Propagation Letters*, Vol. 6, 2017, pp.1476-1479.
- [2] S. Talwar, D. Choudhury, K. Dimou, E. Aryafar, B. Bangerter and K. Stewart, "Enabling technologies and architectures for 5G wireless", *IEEE MTT-S International Microwave Symposium*, 2014, pp.1-4.
- [3] T. Pfeiffer, "Next generation mobile fronthaul and midhaul architectures" *Journal of Optical Communications and Networking*, Vol. 7(11), 2015, pp.B38-B45.
- [4] R.W.Heath, N. Gonzalez-Prelcic, S. Rangan, W. Roh and A.M.Sayeed, "An overview of signal processing techniques for millimeter wave MIMO systems", *IEEE Journal of Selected Topics in Signal Processing*, vol.10(3), 2016, pp.436-453.

- [5] G. Ntogari, T. Kamalakis and T. Spicopoulos, "Analysis of Indoor Multiple-Input Multiple-Output Coherent Optical Wireless Systems", *Journal of Lightwave Technology*, Vol. 30(3), 2012, pp.317-324.
- [6] E. Björnson, M. Matthaiou and M. Debbah, "Massive MIMO with non-ideal arbitrary arrays: Hardware scaling laws and circuit-aware design." *IEEE Transactions on Wireless Communications*, vol.14 (8), 2015, pp.4353-4368.
- [7] Y. Zhang, P. Wang, L. Guo, W. Wang and H. Tian, "Performance analysis of an OAM multiplexing-based MIMO FSO system over atmospheric turbulence using space-time coding with channel estimation", *Optics express*, vol.25(17), 2017, pp.19995-20011.
- [8] A.E. Aighobahi and N.J. Gomes, "Capacity and Error Performance Verification of Multi-Antenna Schemes in Radio-over-Fiber Distributed Antenna System", *Journal of Lightwave Technology*, vol.34 (40), 2016, pp.4779-4785.
- [9] N.J. Gomes, P.P. Monteiro and A. Gameiro, "Radio Over Fiber System Design for Distributed Broadband Wireless System" in *Next Generation Wireless Communications Using Radio over Fiber*, John Wiley & Sons, 2012.
- [10] L. Liu *et al.*, "Characterization of line-of-sight MIMO channel for fixed wireless communications", *IEEE Antennas and Wireless Propagation Letters*, Vol.6, 2007, pp.36-39.
- [11] A. Kanno, T. Kuri, I. Hosako, T. Kawanishi, Y. Yoshida, Y. Yasumura and K.I. Kitayama, "Optical and millimeter-wave radio seamless MIMO transmission based on a radio over fiber technology", *Optics Express*, Vol.20 (28), 2012, pp.29395-29403.
- [12] M. Kong and W. Zhou, "Delivery of 12QAM single carrier signal in a MIMO radio-over-fiber system at 60GHz", *IEEE Photonics Journal*, Vol.9 (3), 2017.
- [13] C.H. Lin, C.T. Lin, H.T. Huang, W.S. Zeng, S.C. Chiang and H.Y. Chang, "60-GHz optical/wireless MIMO system integrated with optical subcarrier multiplexing and 2x2 wireless communication", *Optics Express*, Vol. 23(9), 2015, pp.12111-12116.
- [14] L. Cheng, M.M.U. Gul, F.L.U. M. Zhu, J. Wang, M. Xu, X. Ma and G.K. Chang, "Coordinated Multipoint Transmissions in Millimeter-Wave Radio-Over-Fiber Systems", *Journal of Lightwave Technology*, Vol. 34(2), 2016, pp.653 - 660.
- [15] D. Wake, A. Nkansah and N.J. Gomes, "Radio over fiber link design for next generation wireless systems", *Journal of Lightwave Technology*, Vol.28 (16), 2010, pp.2456-2464.
- [16] A. Lebedev, X. Pang, J. J. V. Olmos, M. Beltran, R. Llorente, S. Forchhammer, and I. T. Monroy, "Feasibility study and experimental verification of simplified fiber-supported 60-GHz picocell mobile backhaul links", *IEEE Photonics Journal*, Vol.5 (4), 2013, pp.7200913-7200913.
- [17] U. Habib, A. Aighobahi, M. Nair, H. Zhu, T. Quinlan, S. Walker and N. J. Gomes, "Performance Improvement for OFDM-RoF Transported 60 GHz System using Spatial Diversity and Multiplexing", *10th International Workshop on Evolutional Technologies and Ecosystems for 5G and Beyond (WDN-5G) IEEE International Conference on Communications ICC*, Paris, 2017.
- [18] U. Habib, A. Aighobahi, T. Quinlan, S. Walker and N. J. Gomes, "Demonstration of Radio-over-Fiber-supported 60 GHz MIMO using Separate Antenna-Pair Processing", *MWP 2017*, Beijing, China.
- [19] T. Quinlan and S. Walker, "A 16.8 dBi quasi-discoidal radiation pattern antenna array for 60GHz non-line-of-sight applications", *Antennas and Propagation Conference (LAPC)*, 2014 Loughborough, 2014, pp.210-213.
- [20] J. Onubogu, K. Ziri-Castro, D. Jayalath, and S. Hajime, "Experimental evaluation of the performance of MIMO-OFDM for vehicle-to-infrastructure communications," *EURASIP Journal on Wireless Communications and Networking*, 2015, vol. 183, pp.1-19.
- [21] K. Zhu, M. J. Crisp, S. He, R. V. Penty and I. A. White, "MIMO system capacity improvements using radio-over-fibre distributed antenna system technology." *Optical Fiber Communication Conference and Exposition (OFC/NFOEC)*, 2011.
- [22] H.M. Oubei, J.R. Duran, B. Janjua, H-Y. Wang, C-T. Tsai, Y-C. Chi, T.K.Ng, H-C. Kuo, J-H. H, M.S. Alouini, G-R. Lin and B.S.Ooi, "4.8 Gbit/s 16-QAM-OFDM transmission based on compact 450-nm laser for underwater wireless optical communication" *Optics Express*, Vol. 23 (18), 2015, pp. 23302-23309.



Usman Habib received the B.Sc. and M.Sc in Electrical Engineering from University of Engineering and Technology, Pakistan in 2009 and 2003, respectively. He is currently working towards the PhD degree in Electronic Engineering at the University of Kent, Canterbury, UK. His research interests include Radio-over-fibre, 60GHz MIMO/CoMP and Beamforming.



Anthony E. Aighobahi received a B.Sc. (Hons.) degree in Computer Science and Information Technology from Igbinedion University, Nigeria in 2009, Masters degree in Electronic Engineering from Manchester Metropolitan University in 2012 and PhD degree in Electronic Engineering at the University of Kent in 2017. He is currently a Lecturer in Electrical/ Electronics Engineering at Achievers University, Nigeria. His research involves the experimental investigation of MIMO schemes for RoF-DAS.



Terence Quinlan joined the Access Networks group at the University of Essex in 1990. As a result he has published over 90 journals and refereed conference papers in the fields of optical and microwave communications. Initially working on projects involving self-pulsating lasers and sub-carrier multiplexing, this was followed by a BT funded project on the low power optical transmission of VDSL. He then assisted with the MUSE (Multi User Service

Everywhere) project followed by UROOF (Ultra-Wide-band Radio over Fibre) which developed the use of reflective transducers and VCSELs to transmit Wimedia UWB up to 1km. Subsequently was the EU FP7 FIVER project, this involved pioneering work on the simultaneous transmission of multiple format wireless systems over optical fibre up to a distance of 100km. He then went work on the SODALES EU FP7 and NIRVANA projects and the EU funded Horizon 2020 iCIRRUS and CHARISMA projects, researching novel mm wave antenna and circuit designs. He completed an MSc by Dissertation in 2008 on "Multi-gigabit Patch Antenna Design" and completed his PhD on "Phase Contrast Microwave Detection Techniques" in 2015.



Stuart D. Walker was born in Dover, U.K., in 1952. He received the B.Sc. (Hons.) degree in physics from Manchester University, Manchester, U.K., in 1973, the M.Sc. degree in telecommunications systems and the Ph.D. degree in electronics from the University of Essex, Colchester, U.K., in 1975 and 1981, respectively. From 1981 to 1982, he was a Post-Doctoral Research Assistant with the University of Essex, a Research Scientist at BT Research Laboratories from 1982 to

1987, and was promoted to Group Leader of Submarine Systems Design. He joined the University of Essex in 1988 as a Senior Lecturer, and was promoted to Reader in 2002 and Full Professor in 2004. He currently manages a laboratory concerned with all aspects of access networks. He has been involved in many EPSRC and European Union Research Projects over the years, e.g., e-Photon-I and II, BONE, MUSE-I and II, UROOF, STRONGEST, FIVER, and OASE. More recently, has worked on the SODALES Framework 7 project, which involved LTE, WiMAX, WiFi, 802.11ad, and UWB wireless systems together with UHD TV compression and transmission. He is currently a collaborator on the EPSRC NIRVANA and H2020 iCirrus and CHARISMA projects. He has published over 250 peer-reviewed journal and conference papers, and holds four patents. He has served as a reviewer of the IET, IEEE, IOP and OSA Journals, Dutch, Polish, and American Government and U.K. EPSRC research proposals.



Nathan J. Gomes (M'92-SM'06) received the B.Sc. degree from the University of Sussex, Sussex, U.K., in 1984, and the Ph.D. degree from University College London, London, U.K., in 1988, both in electronic engineering. From 1988 to 1989, he held a Royal Society European Exchange Fellowship with ENST, Paris, France. Since late 1989, he has been with the University of Kent, Canterbury, U.K., where he is currently

Professor of Optical Fibre Communications. His current research interests include fiber-wireless access, and RoF systems and networks. Professor Gomes was a TPC Co-chair for the MWP 2014 IEEE Topical Meeting in Sapporo and TPC Chair for IEEE International Conference on Communications, ICC 2015 in London.