

Video Streaming in Evolving Networks under Fuzzy Logic Control

Martin Fleury, Emmanuel Jammeh, Rouzbeh Razavi,
Sandro Moiron and Mohammed Ghanbari
*University of Essex
United Kingdom*

1. Introduction

Internet Protocol TV (IPTV) and other video streaming services are expected to dominate the bandwidth capacity of evolving telecommunications networks. In fact, managed, all-IP networks are under construction with video largely in mind. In these networks, a variety of broadband access networks will form the final link to the home across which video is streamed from proprietary servers. Co-existing with these networks or as an extension of them, the traditional, best-effort Internet will continue to support applications such as video-on-demand, Peer-to-Peer (P2P) streaming, and video clip selection.

This Chapter will begin by broadly surveying research and development of video streaming across evolving telecommunications networks under the categories of best-effort and managed networks. In particular, the Chapter will introduce the different forms of control that are necessary to ensure the quality of the delivered video, whether live or pre-encoded video, when for the latter bitrate transcoding may be required. The concentration will be on single-layer unicast distribution though simulcast, bandwidth reservation, multicast, and other forms of delivery will be touched upon.

With the growth in computational power, rate-distortion (R-D) control has emerged as an effective way to optimise the output encoded bitstream. In R-D control, the optimal choice of compression rate (and hence codec output bitstream rate) relative to improvement in video quality is sought. (The choice is generally found through the method of pre-set Lagrangian multipliers with trial codec settings repeatedly tested to find the best result.) Though attempts have been made to integrate R-D control and network congestion control (Chou & Miao, 2006), often congestion control has been considered separately as best-effort networks are prone to fluctuations in available bandwidth. In all-IP networks, though traffic in the core of the network will be switched, the variety of access network types poses a problem to servers that may be oblivious of the final hop technology. When broadband wireless (IEEE 802.16 d,e, WiMAX (Fleury et al., 2009)) access links are involved error control is especially important.

The Chapter will then specialise to consider in what ways fuzzy logic controllers (FLCs) have been applied to rate control and congestion control. A feature of this Chapter will be consideration given to the growing prominence of type-2 fuzzy logic in networked

multimedia control, bringing greater robustness in the face of unforeseen network conditions. To illustrate the application of fuzzy logic control, the Chapter will include two case studies. One of these will show how type-2 logic can improve upon type-1 logic, both of which forms of congestion control improve upon traditional controllers respectively within managed networks and within the Internet. The design of the controllers is illustrated for non-specialists, showing how type-2 controllers extend type-1 FLCs. From the results of simulations, FLCs in a managed network are shown to be superior to traditional congestion controllers. Transcoding is presented as an effective way to apply fuzzy logic control.

With the advent of IPTV, statistical multiplexing has again become an important issue for managed networks. Unlike traditional broadcast channels, network distribution may involve changes in available bandwidth and streaming conditions because of the variety of possible access types and coexisting traffic. In the second case study, an FLC is used to integrate two video complexity measures to achieve an effective combination of video or TV channels. The intention is dynamically to reduce the bandwidth allocation to channels that are already of high enough quality and increase the quality of streams with potentially greater coding complexity. Simulation results are presented to show the value of the approach applying the state-of-the-art H.264 codec. This case study will also include a review of other forms of statistical multiplexing.

2. Video streaming

2.1 Streaming basics

In video streaming, the compressed video bitstream is transmitted across a network to the end user's decoder (prior to display) without the need for storage other than in temporary buffering. Its advantage over progressive download from a network point-of-view is that the throughput is only that required to render the video at the user's display. Download risks overloading the network by too high a throughput. If download is not progressive, then the user has to wait an intolerable time before (say) viewing a 2 hr movie. There are also issues of commercial confidentiality if the video is stored on the user's machine.

Downloading video does permit Variable Bitrate (VBR) to be transported. In VBR, the codec quantization parameter (QP) is fixed leading to a constant quality. The alternative is to set a target bit rate for Constant Bitrate (CBR) video and allow fluctuating quality but with a gain in controllability. The main problem with VBR is that due to a strong variation in the number of bits allocated to each of the frame types (Lakshman et al., 1998) the rate is highly variable (Van der Auwera & Reisslein, 2009). Long video streams are also not statistically stationary in time, which causes a problem when attempting to model video input to a network. This variability is accentuated in the H.264/Advanced Video Codec (AVC) (Schwarz, 2007) and it is reported (Van der Auwera et al., 2008) that the variability is accentuated the more so in the Scalable Video (SVC) extension to H.264, with the result that prior smoothing of VBR streams is contemplated. (The reason for increased variability is attributable to the increased number of motion estimation modes in H.264/AVC and in H.264/SVC, the addition of hierarchical B-frames.)

In temporal smoothing, multiple encoded frames are accumulated so that the compressed bitstream can be packetized and sent at a desired average bitrate. This form of traffic shaping has the disadvantage for video streaming that end-to-end latency is increased by the number of frames accumulated. For 'conversational' video services, which have an

additional latency introduced by the need to encode each frame, the effect on the viewer can be disconcerting. Ideally end-to-end latency should be no longer than 200 ms. For this reason, in services such as teleconferencing and videophone, CBR is preferable. However, for pre-encoded video at a significant cost in computational complexity (Salehi et al., 1998) it is also possible through optimal smoothing to send video frames (or rather their compressed bitstream) in advance of their decode time, provided it is known that overflow (or underflow) at the playback buffer will not occur. In the best-effort Internet, jitter introduced by cross-traffic congestion will disrupt these calculations but in those network cores in which ATM or virtual ATM is still in place optimal smoothing has a role. Unfortunately, the presence of access networks of differing types prior to the consumer's home, or reduced bandwidth links prior to campus and corporate networks introduces an ill-behaved section within the end-to-end path.

Video is known as a delay-sensitive service but in fact there are varying levels of intolerance, and a limit of 200 ms has been mentioned. However, for one-way streaming the delay requirements are less stringent. For example, channel swapping or VCR-like control is restricted to 500 ms intervals, because anchor or key frames at which switching can occur are placed at these intervals within a stream. Another form of delay is start-up delay, with Video-on-Demand (VoD) services hoping to make this imperceptible (< 20 ms), which is perhaps possible on the Internet if the Resource ReSerVation Protocol (RSVP) (Zhang et al., 1997) were to be widely deployed. Variation in delay (jitter) is also important in terms of media synchronization (between audio and video) (Blakowski & Steinmetz, 1996). However, there are also display deadlines to be met, implying that a jitter buffer should be dimensioned to absorb any variation in delivery (assuming Internet delivery). For reference frames (one used for predictive motion estimation), their data is still of value for decoding future frames even if they miss their display deadline. Too large a receiver buffer will lead to increased end-to-end latency and start-up delay, while too small a buffer may cause overflow. This is why adaptive buffers have been contemplated in the research literature (Kalman et al., 2002).

Video streaming is also known as a loss-tolerant service. However, this is misleading as the loss of more than 10% of packets will generally lead to a noticeable deterioration in the quality of the video unless: error-resilience measures have been taken; error control through some form of acknowledgements (ACKs) is used (as in the Windows Media system); Forward Error Correction (FEC) is in place; or error concealment can be applied. A combination of these methods is preferable as part of an error response strategy and unequal error protection (UEP) is possible. In UEP, protection is prioritized according to compressed video content or the structure of the video. Acknowledgments are possible but their impact on delay must always be judged. For example, in (Mao et al., 2003) layered streaming was attempted across an ad hoc network in which multi-hop routing and broken links can lead to high levels of delay. In layered streaming (Mao et al., 2003), a more important base layer allows a basic reconstruction of the video while one or more enhancement layers can improve the quality. However, because of the high risk of delay, in (Mao et al., 2003) it was only possible to send one ACK at most to secure the base layer.

Though FEC schemes with linear decoder complexity (Raptor codes, a variety of rateless erasure codes) have been developed (Shokrollahi, 2006), FEC generally leads to delay in encoding. Because of the additional delay involved in sending acknowledgments (or negative acknowledgments), when there is a long round-trip-time careful engineering needs

to be applied if rateless erasure coding is to be used. In rateless or Fountain coding (MacKay, 2005), additional redundant data can always be generated, while in conventional forms of channel coding such as Reed-Solomon, there is a threshold effect whereby if the channel noise or packet erasures pass the level of protection originally provided then all data are lost.

Error resilience techniques, the range of which have been expanded in the H.264 codec (Wenger, 2003), are based on source coding. Error resilience results in lower-delay and as such is suitable for real-time, interactive video streaming, especially video-telephony and video conferencing. However, due to the growing importance of broadband wireless access networks, error resilience is also needed to protect video streaming to the home. This is because physical-layer FEC is already present and, therefore, application-layer FEC may duplicate its role. The exception is if application-layer FEC can be designed to act as an outer code after inner coding at the physical layer, in the manner of concatenated channel coding.

Compressed frame data is often split into a number of slices each consisting of a set of macroblocks. In the MPEG-2 codec, slices could only be constructed from a single row of macroblocks. Slice resynchronization markers ensure that if a slice is lost then the decoder is still able to continue with entropic decoding. Therefore, a slice is a unit of error resilience and it is normally assumed that one slice forms a packet, after packing into a Network Abstraction Layer unit (NALU) in H.264. Each NALU is encapsulated in a Real Time Protocol (RTP) packet. Consequently, for a given frame, the more slices the smaller the packet size and the less risk of packet loss through bit errors.

In H.264/AVC, by varying the way in which the macroblocks are assigned to a slice (or rather group of slices), Flexible Macroblock Ordering (FMO) gives a way of reconstructing a frame even if one or more slices are lost. Within a frame up to eight slice groups are possible. A simple FMO method is to continue a row of macroblocks to a second row, Figure 1a, but allow disjoint slice groups (Lambert et al., 2006). Regions of interest are supported, Figure 1b. Checkerboard slice group selection, Fig. 1c allows one slice group to aid in the reconstruction of the other slice group (if its packet is lost) by temporal (using motion vector averaging) or spatial interpolation. Assignment of macroblocks to a slice group can be general (type 6) but the other six types pre-define an assignment formula, thus reducing the coding overhead from providing a full assignment map.

Data partitioning in H.264/AVC separates the compressed bitstream into: A) configuration data and motion vectors; B) intra-coded transform coefficients; and C) inter-coded coefficients. This data form A, B, and C partitions which are packetized as separate NALUs. The arrangement allows a frame to be reconstructed even if the inter-coded macroblocks in partition C. are lost, provided the motion vectors in partition A survive. Partition A is normally strongly FEC-protected at the application layer or physical layer protection may be provided such as the hierarchical modulation scheme in (Barmada et al., 2005) for broadcast TV. Notice that in codecs prior to H.264, data partitioning was also applied but no separation into NALUs occurred. The advantage of integral partitioning is that additional resynchronization markers are available that reset entropic encoding. This mode of data partitioning is still available in H.264 and is applied to I-frames.

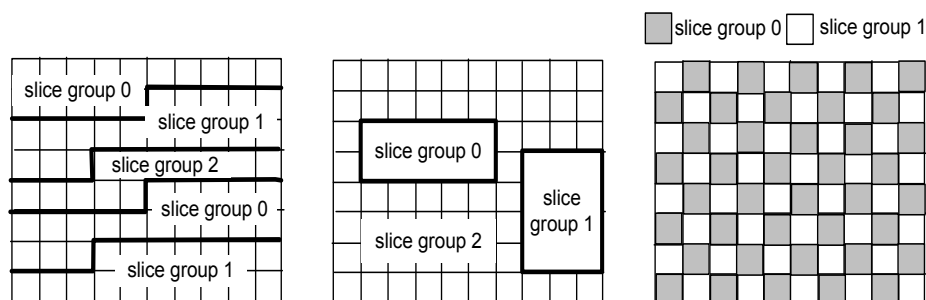

Fig. 1. Example FMO slice groups and types (after (Lambert, 2006) a) Continuing row (type 0) b) geometrical selection (type 2) c) checkerboard selection (type 1)

The insertion of intra-coded macroblocks into frames normally encoded through motion-compensated prediction allows temporal error propagation to be arrested if matching macroblocks in a previous frame are lost. Intra-refresh through periodic insertion of I-frames with all macroblocks encoded through spatial reference (intra-coded) is the usual way of catching error propagation. However, I-frames cause periodic increases in the datarate when encoding at a variable bitrate. They are also unnecessary if channel switching points and VCR functions are not required.

This brief review by no means exhausts the error-resilience facilities in H.264, with redundant frames, switching frames, and flexible reference frames also considered in (Stockhammer & Zia, 2007). We have referred to H.264/AVC anchor frames as I-frames for consistency with previous codecs. In fact, H.264 uses Instantaneous Decoder Refresh (IDR)-frames for the same purpose, whereas H.264 I-frames allow motion estimation reference beyond the Group of Pictures boundary.

Error concealment (Wang & Zou, 1998) is the process of concealing errors at the decoder. However, the form of error concealment is implementation dependent because of the complexity of these algorithms. In fact, for reasons of speed, previous frame replacement is often preferred. If lost frames are replaced by the last frame to arrive successfully there is a danger of freeze frame effects. When there is rapid motion or scene cuts then partial replacement of macroblocks from the previous frame will result in obvious blocky effects. For error concealment in H.264/AVC (Vars & Hannuksela, 2001) the motion vectors of correctly received slices are computed if the average motion activity is sufficient (more than a quarter pixel). Research in (Vars & Hannuksela, 2001) gives details of which motion vector to select to give the smoothest block transition. It is also possible to select the intra-coded frame method of spatial interpolation, which provides smooth and consistent edges at an increased computational cost. Experience shows a motion-vector-based method performs best except when there is high motion activity or frequent scene changes (Kim & Kim, 2002).

2.2 Streaming systems

In networked video delivery, systems are classically divided (Chou, 2007) into streaming and broadcast systems. In the former, video is pre-encoded before storage and access by a server, while in the latter there is no storage before server access and multicast over a network. A further distinction in this model is that in streaming a control path exists, whereas the presence of many receivers in a broadcast system means that feedback would

be impossible to manage. Feedback can be used for congestion control but it can also return VCR commands, typically through the Real Time Streaming Protocol (RTSP) (Schulzrinne et al., 1998). Nevertheless, it is possible to stream both pre-encoded and online or live video because, after feedback notification of congestion, the streaming rate can be changed through bitrate transcoding (Assunção & Ghanbari, 1997) (Sun et al., 2005). One problem that fast transcoding may face in the H.264 codec is error drift when transcoding I-frames (Lefol et al., 2006).

Scalable video also allows rate control as a response to network conditions or target device capability but a full discussion of the variety of multi-layer or scalable options such as Fine Grain Scalability (Radha et al., 2001), Multiple Description Coding (Wang, 2005), signal-to-noise ratio (SNR) scalability (Pesquet-Popescu et al., 2006) would require another chapter. Rich though the scalable options are commercial Internet operators seem to prefer simple schemes such as simulcast as used by RealVideo. In simulcast, multiple streams are stored (or encoded online) at different rates and selected according to network conditions. In H264/AVC, stream switching frames allow a smoother transition between low and higher quality stream at lower cost in bandwidth than through switching at I-frames.

At the target device, video is first buffered in a playout buffer, decoder or client buffer (there are various alternative names) prior to access by the decoder. This buffer will vary in size depending on the capabilities of the device. Large buffers are not advisable for battery-powered devices because of both active and passive energy consumption. Nevertheless some buffering is required to absorb variation of delay (jitter) over the network.

Because of motion-compensated prediction coding it is always necessary to store packets prior to decode, especially if VBR is in use. An additional render buffer, able to store a few frames prior to display, is also generally present. Apart from buffer overflow in the intermediate buffers of routers through congestion, buffer overflow at the playout buffer is also possible. Packets arriving too late for their display or decode deadlines may also be dropped. It is also possible, because of jitter, for buffer underflow to occur. In fact, in the Windows Media system (Chou, 2007) the receiver monitors the buffer level to detect network congestion. Again like RealVideo, Windows Media uses simulcast, with the receiver signaling the server to swap to a lower rate stream when it detects congestion. However, the Windows Media receiver or client is not only reliant on buffer monitoring, because packet loss at the receiver is also taken into account.

3. Congestion control

In this Section, the focus is on congestion control of single stream unicast for IPTV and other multimedia services. Because the main thrust in congestion control research is to provide an enhanced service through VBR delivery, this Section concentrates on that whereas in Section 4 on statistical multiplexing, multi-channel delivery of CBR streams is considered. The latter is likely to be a broadcast service.

3.1 IPTV and unicast streaming

Real-time video applications, such as IPTV, video-on-demand (VoD), and network-based video recorder interest telecommunication companies, because of their high bitrates, though they also risk overwhelming existing networks if it is not possible to control their flows. The unicast variety of IPTV is very attractive because it allows streaming of individual TV

programs at a time chosen by the end user. Broadly speaking, two types of heterogeneous delivery network exist: 1) the familiar Internet, with best-effort Internet Protocol (IP) routing, i.e. an unmanaged IP network; and 2) All-IP networks, which retain IP packet framing but, particularly in the network core, switch packets (across Clos switches) rather than employ packet routers, i.e. a managed IP network. These IP networks are generally referred to as converged networks, as they combine a traditional telephone service (through Voice-over-IP) with data delivery (normally high speed Internet access) and TV (through IPTV). The marketing term for such a combined service is 'triple-play' and if mobility is added then this term becomes 'quadruple-play'.

IPTV services are in active commercial development for converged telephony networks, such as British Telecom's 21st Century Network (21CN) (Geer, 2004) or the all-IP network of KPN in the Netherlands. Within the 21CN, video streaming is sourced either from proprietary servers or from an external Internet connection, with best-effort routing. Before distribution from the server to individual users, multiple videos streams will share a multimedia channel, an example being MPEG-2 Transport Stream which serves for H.264/AVC pre-encoded streams. These video streams could represent different TV channels that can be selected by the IPTV user. However, when the multimedia channel leaves the core network it is commonly delivered across an access network such as Asymmetric Digital Subscriber Line (ADSL) (Zheng & Liu, 2000), when different delivery conditions apply.

On the Internet, video streams must coexist with other data traffic, while in emerging All-IP networks multimedia traffic may predominate. In an All-IP network, as in the Internet, a capacity restriction may still exist at the connection between the network core and the access network, of which the technology can be cable (Vasudevan et al., 2008), broadband wireless (IEEE, 2004), or connections to the Video Serving Office (Han et al., 2008) from which video is typically distributed over Asymmetric Digital Subscriber Line (ADSL) connections. Note also that Internet traffic may be directed through an All-IP network by means of the common agency of IP framing.

In the Internet, a tight link (or more loosely a bottleneck), which commonly exists at the network edge before a corporate or campus network (Cisco, 2000), is the link of minimum available bandwidth on a network path. Strictly the term 'bottleneck' defines the bandwidth capacity of a network path, which while the path exists is a constant, though the term may also be loosely applied to a tight link. A tight link is a dynamic concept, as its location will vary firstly over time according to background traffic patterns and secondly according to the network path's route, which is not fixed because of dynamic routing on the Internet. These two factors can create uncertainty in any video streaming response. Available bandwidth is restricted by coexisting cross-traffic, which is most likely carried by the Transmission Control Protocol (TCP) and predominantly originates from web-servers or P2P file transfer (Xie et al., 2007). Transport-layer protocols like TCP, sitting above IP, are responsible for end-to-end negotiation of delivery between applications. On All-IP networks, coexisting traffic across a network sub-channel or pipe is more likely to arise from other proprietary video servers and be carried by the minimal User Datagram Protocol (UDP) as directed by congestion controllers. A pipe is a virtual bandwidth restriction imposed by quality-of-service requirements that must balance the requirements of other types of traffic and the capacity of the access network. As in the Internet, All-IP congestion controllers should be end-to-end over the network path, allowing a general solution in the sense that the nature of the access network

bottleneck may not be known in advance. In an All-IP network, statistical multiplexing of VBR video sources within a video pipe may increase its efficiency but there is no spare capacity for greedy acquisition of bandwidth by independently controlled video servers. We return to the subject of statistical multiplexing within the IPTV pipe in Section 4.

Congestion control is vital to avoid undue packet loss from the fragile compressed video stream. At the sub-frame level, because variable-length coding (VLC) prior to outputting the bitstream introduces a dependency between each encoded symbol, there is fragility that error resilience techniques such as decoder synchronization markers and reversible VLC only partially address. Because successive video frames are broadly similar (except at scene cuts and changes of camera shots), only the difference between successive frames is encoded in order to increase coding efficiency. Consequently, at the frame-level, removing temporal redundancy introduces a dependency on previously transmitted data that implies lost packets from reference frames will have an impact on future frames.

Unicast video streaming, which brings increased flexibility and choice to the viewer over multicast delivery, is achieved by determining the available bandwidth and adapting the video rate at a live video encoder or an intermediate transcoder. Fuzzy Logic Control (FLC) is suited to congestion control (Jammeh et al., 2007), because of the inherent looseness in the definition of congestion and the uncertainty in the network measurements available, together with the need for a real-time solution. Within video coding it has previously found an application (Grant et al., 1997) in maintaining a constant video rate by varying the encoder quantization parameter according to the output buffer state. This is a complex control problem without an analytical solution. Fuzzy logic is gaining acceptance in the video community, witness (Rezaei et al., 2008), but it turns out that further improvements are possible with interval type-2 (IT2) fuzzy logic.

3.2 Fuzzy logic control for congestion

In our application, FLC of congestion is a sender-based system for unicast flows. The receiver returns a feedback message indicating changes to the delay experienced by video stream packets crossing the Internet. This allows the sender to compute the network congestion level and from that the FLC estimates the response. The same controller also should be able to cope with a range of path delays and with video streams with differing characteristics in terms of scene complexity, motion, and scene cuts.

Traditional, type-1 FLC is not completely fuzzy, as the boundaries of its membership functions are fixed. This implies that there may be unforeseen traffic scenarios for which the existing membership functions do not suffice to model the uncertainties in the video stream congestion control task. IT2 FLC can address this problem by extending a Footprint-of-Uncertainty (FOU) on either side of an existing type-1 membership function. In IT2 fuzzy logic, the variation is assumed to be constant across the FOU, hence the designation 'interval'. Though the possibility of type-2 fuzzy systems has been known for some time (Zaddeh, 1975), only recently (Mendel, 2007) have algorithms become available to calculate an IT2 output control value at video rate. The first IT2 controllers (Hagras, 2007) are now emerging, in which conversion or retyping from fuzzy IT2 to fuzzy type-1 takes place before output. For video streaming there are important practical advantages. Not only does such a controller bring confidence that re-tuning will not be needed when arriving traffic displays unanticipated or un-modeled behavior but the off-line training period required to form the membership functions can be reduced.

We now compare type-1 FLC for congestion control of video streaming to an IT2 FLC and compare the performance in the presence of measurement noise that is artificially injected to test the relative robustness. The delivered video quality in terms of Peak Signal-to-Noise Ratio (PSNR) is equivalent to the successful type-1 FLC when the measurement noise is limited and under test results in a considerable improvement when the perturbations are large. We go on to compare the IT2 FLC to a non-adaptive approach and to congestion control by two well-known controllers, TCP-friendly Rate Control (TFRC) (Handley et al., 2003) and TCP Emulation at Receivers (TEAR) (Rhee et al., 2000), one sender-based and the other receiver based. These are tested by their ability to support multiple broadband connections over an all-IP network. However, firstly we introduce fuzzy logic control.

3.3 Fuzzy logic control

Figure 2 is a block diagram of FLC of congestion, with two inputs, the packet delay factor, df , and delay samples to form a trend (whether packet delay is increasing or decreasing). The formation of these inputs is described in Section 3.4. These inputs are converted to fuzzy form, whereby their membership of a fuzzy subset is determined by predetermined membership functions. This conversion takes place in the fuzzifier and trend test units of Figure 1. The fuzzy outputs are then combined in the inference engine through fuzzy logic. Fuzzy logic is expressed as a set of rules which take the form of linguistic expressions. These rules express experience of tuning the controller and, in the methodology, are captured in a knowledge database. The inference engine block is the intelligence of the controller, with the capability of emulating the human decision making process, based on fuzzy-logic, by means of the knowledge database and embedded rules for making those decisions. Lastly, the defuzzification block converts inferred fuzzy control decisions from the inference engine to a crisp or precise value, which is converted to a control signal. The control signal causes the quantization parameter of the video stream to be changed, thus adjusting the output bitstream.

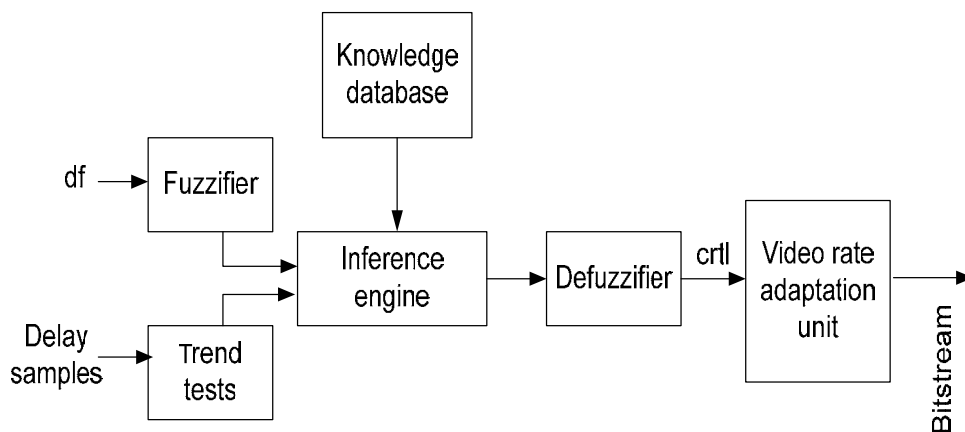

Fig. 2. FLC delay-based congestion controller

In a fuzzy subset, each member is an ordered pair, with the first element of the pair being a member of a set S and the second element being the possibility, in the interval $[0, 1]$, that the member is in the fuzzy subset. This should be compared with a Boolean subset in which every member of a set S is a member of the subset with probability taken from the set $\{0, 1\}$, in which a probability of 1 represents certain membership and 0 represents non-membership.

The FLC determines incipient congestion from one way packet queuing delay in intermediate router buffers. The queuing delay is a measure of network congestion, and the ratio of the average queuing delay to the maximum queuing delay is a measure of bottleneck link buffer fullness. For each received packet indexed by i

$$OWDi = Tr - Ts, \quad (1)$$

where Tr is the receive time of the current packet and Ts is the time the packet was sent. When it is appropriate, the computed $OWDi$ updates the minimum and maximum one-way delays ($OWDs$), $OWDmin$ and $OWDmax$, on a packet-by-packet basis. Subsequently, the maximum queuing delay is found as $maxQD = OWDmax - OWDmin$.

The queuing delay over the network path, QDi is computed from the measured delay and the minimum delay:

$$QDi = OWDi - OWDmin \quad (2)$$

and an exponentially-weighted average of the queuing delay for the i th received packet is formed by,

$$avgQDi = (1 - a) \times avgQDi-1 + a \times QDi \quad (3)$$

where $a \leq 1$ is a forgetting constant. In tests, a was set to 0.1. A delay factor, Df , is computed from the average queuing delay and the maximum queuing delay,

$$Df = avgQDi / maxQD \quad (4)$$

where Df ranges between $[0,1]$ with 0 indicating no incipient congestion, 1 indicating full-blown congestion, with shades of incipient congestion between 0 and 1. Df is an early notification of congestion and is the first input to the FLC.

A trend analysis method is used to determine the general trend of the average delay. In each measurement epoch, a number k of queue delay samples are grouped into τ groups where $\tau = \sqrt{k}$. We use the pairwise comparison test (PCT) to determine the overall trend of the queuing delay as shown in (5).

$$T_{PCT} = \frac{\sum_{i=2}^{\tau} I(M^i > M^{i-1})}{\tau - 1} \quad (5)$$

where M^i is the median of group i and $I(X)$ is 1 if X holds and 0 otherwise. The value of T_{PCT} is sent back to the sender where a fuzzifier determines whether the level was increasing or not according to a membership function.

IT2 input membership functions for Df and trend are constructed, Figure 3, as an extension of the type-1 FLC through an FOU at the boundaries of the formerly crisp (fixed) membership functions. Assuming the usual singleton input of Df (or T_{PCT}), an interval set requires just an upper and lower value to be resolved to form the resulting FOU in the corresponding output set. For example, Figure 4 shows two IT2 membership functions for input sets A and B, each with an FOU. Singleton input X is a member of each with different degrees of membership. Strictly, an infinite number of membership functions (not all necessarily triangular) can exist within the FOUs of sets A and B, but IT2 sets allow the upper and outer firing levels to be taken, as shown in Figure 4. The minimum operator (\min) acts as a t -norm on the upper and lower firing levels to produce a firing interval.

The firing interval serves to bind the FOU in the output triangular membership function shown to the right in Figure 4. The lower trapezium outlines the FOU, which itself consists of an inner trapezoidal region that is fixed in extent. The minimum operator, also used by us as a t -norm, has the advantage that its implementation cost is less than a product t -norm. (A t -norm or triangular norm is a generalization of the intersection operation in classical logic.) Once the FOU firing interval is established, Center-of-Sets type reduction was applied by means of the Karnik-Mendel algorithm, which is summarized in (Mendel, 2007). Type reduction involves mapping the IT2 output set to a type-1 set. In practice, defuzzification of this type-1 output fuzzy set simply consists of averaging maximum and minimum values. The result of defuzzification is a crisp value that determines the change in the video rate.

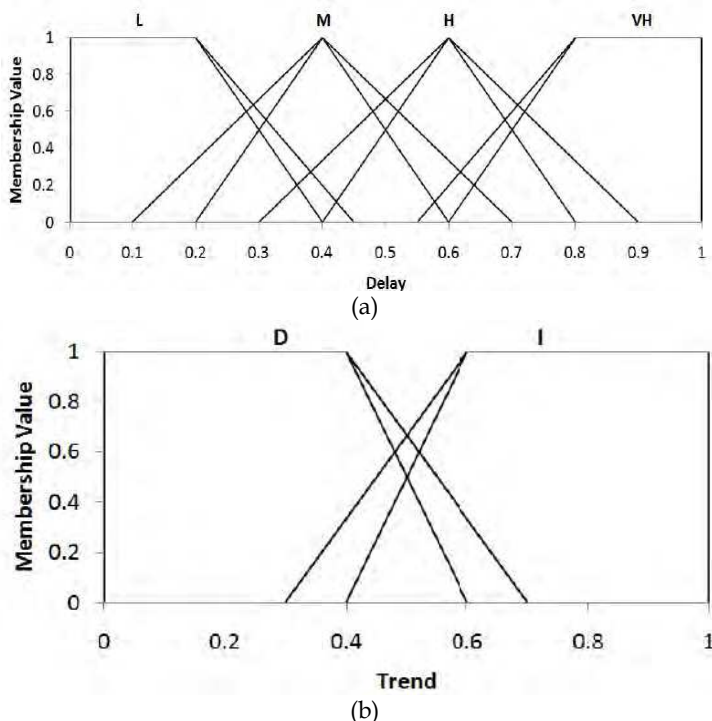

Fig. 3. IT2 FLCC (a) Delay factor (Df) (b) Trend membership functions.

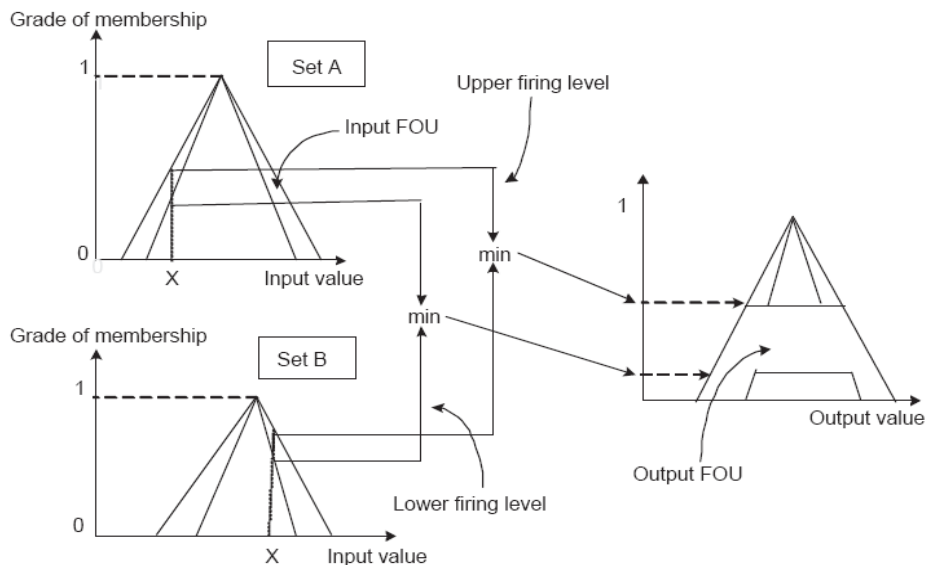

Fig. 4. IT2 FL calculation of output FOU

Figure 5 shows the streaming architecture in which fuzzy logic controls the sending bit rate. The congestion level determination (CLD) unit finds the congestion state of the network from measured delay and delay variation made by the timer module. The congestion state data are relayed to the sender. FLC employs this delay information to compute a new sending rate that is a reflection of the current sending rate and the level of network congestion. The video rate adaptation unit (either a bitrate transcoder adapting pre-encoded video or an encoder adapted through its quantization parameter) changes the sending rate to that computed by the fuzzy controller. The current implementation changes the quantization level of a frequency-domain transcoder (Assunção & Ghanbari, 2000) for VBR video. Full decode and re-encode is prohibitively time consuming. Prior approaches relied on estimation of the error introduced by re-quantization without taking account of the impact on motion estimation by reconstructing the picture and reusing information in the bitstream (Vetro et al., 2005), which still introduces delay, whereas partially (entropic) decoding and motion estimation in the transform domain is faster.

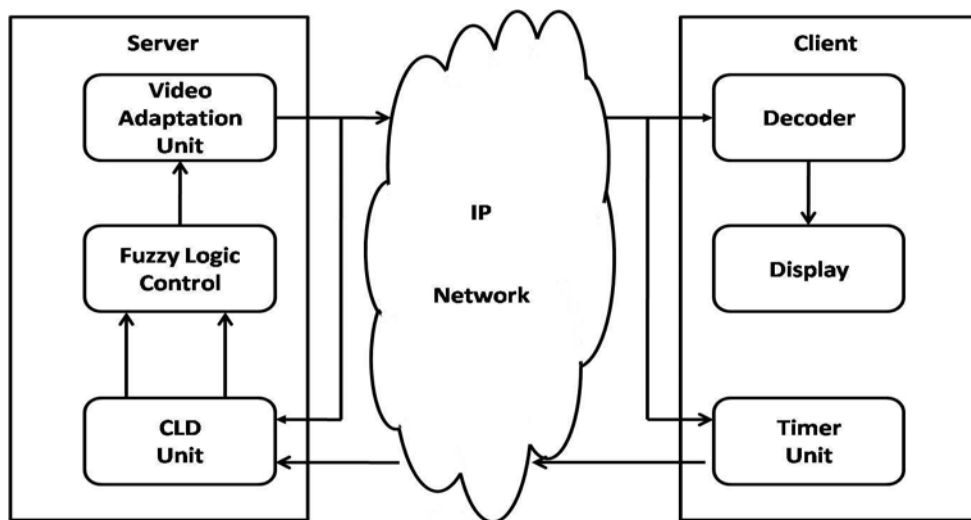

Fig. 5. Video server for all-IP network

Figure 6 shows one instance of server and client. VoD mode, IPTV or video clip services there are multiple video streams and multiple clients. Figure 6 assumes a bank of such servers delivered over an access network such as ADSL or ADSL2+, with downstream rates to 24 Mbps and beyond, one of the passive optical network types (PON) terminating in 100 Mbps Ethernet or coaxial cable, or broadband wireless such as IEEE 802.16 (WiMAX).

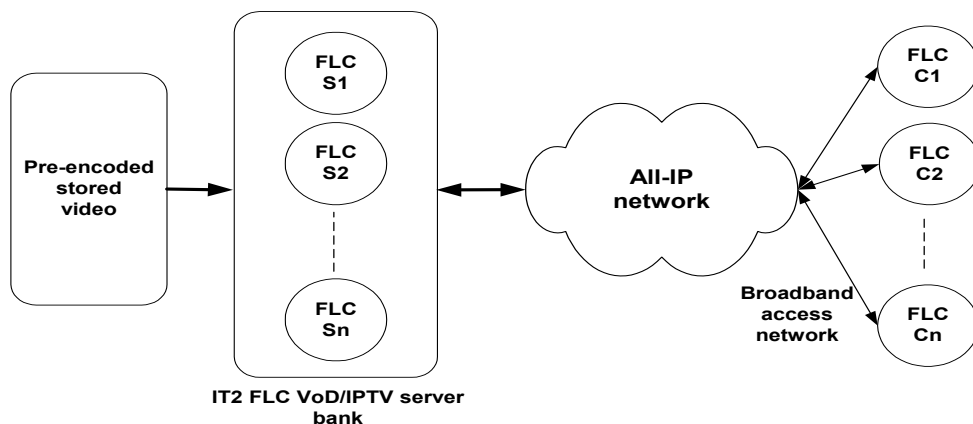

Fig. 6. VoD IPTV video delivery architecture

3.4 Evaluation

FLC congestion controller employs delay and its variation to gauge the state of the network. There is, however, inherent noise in the measurement of delay, including packet timestamps with limited resolution and unresolved clock drift between sender and receiver. These uncertainties in the input to an FLC will potentially impact its performance.

The well-known ns-2 network simulator (v. 2.32) was used, with the type-1 and IT2 FLC implemented as new protocols within ns-2. A normal distribution generated a random noise value with zero mean and a specified standard deviation, determined by the level of noise required and dynamically adjusted relative to the measured (simulated) value. For each simulation the level of additional noise was incrementally increased. At each incremental step, the performance of the two controllers was compared in terms of rate adaptation accuracy, packet loss rate, and delivered video quality (PSNR). Input was a 40 s MPEG-2 encoded video clip, showing a newsreader with a changing backdrop, with moderate movement. The VBR 25 frame/s Standard Interchange Format (SIF)-size clip had a Group of Pictures (GOP) structure of $N=12$, $M=3$ where N is the number of pictures (frames) between each Intra-coded picture and M is the number of pictures between each prediction-coded picture within the GOP (Ghanbari, 2003). For error resilience purposes, there was one slice per packet, resulting in 18 packets per frame. The FLC controllers adjusted their rate every frame. In this set of tests the encoded video was stored at a mean rate of 1 Mbps. The video streams were passed across a bottleneck link restricted to 400 kbps in capacity.

The results are gathered in Table 1, and Figs. 7–8. Below 30% additional noise, the two controllers do not significantly deviate. However, beyond 30% of additional noise, the IT2 FLC congestion controller showed significant improvement over the type-1 FLC in terms of reduced fluctuation in the sending rate and a reduced packet loss rate, both of which will be reflected in better average delivered video quality. The smoothness of the transmission rate (measured by a reduction in the standard deviation of the delay on a per-packet basis) is important in video transport as a fluctuating compressed bit-rate implies a fluctuation in video quality, which is more disconcerting to a viewer than a stream of consistent quality, even if that average quality was lower than that of a fluctuating stream. Figure 8 confirms that delivered average video quality is improved, though, for very high levels of measurement noise, the encoded video stream is so corrupt it matters little which FLC is in control, the quality is very poor. Detailed statistical examination of these results has confirmed their significance within 90% confidence intervals.

Noise level (%)	Type-1	Type-2
0	77.527	76.722
10	78.192	76.607
20	78.986	77.098
30	80.281	77.677
40	109.927	77.747
50	193.612	78.244
60	227.173	80.238
70	230.016	84.294
80	230.651	93.822
90	230.924	113.355
100	231.082	124.652

Table 1. Standard deviation of FLC type-1 and type-2 sending rates (kbps)

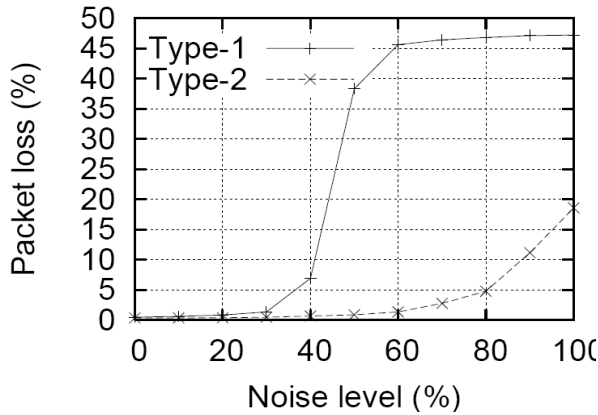

Fig. 7. Packet loss rate for an increasing noise level

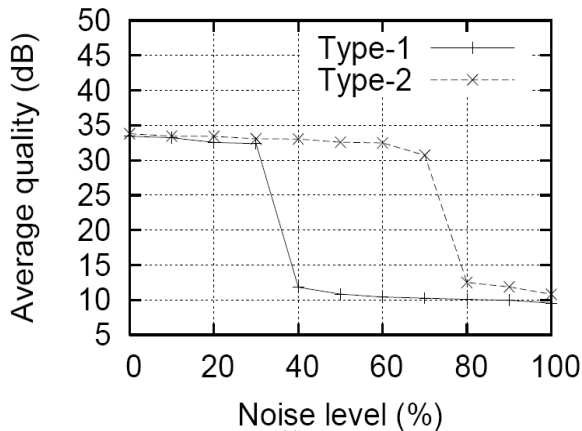

Fig. 8. Mean received video quality for an increasing noise level

Comparison was also made with the TFRC protocol, the subject of an RFC (Handley et al., 2003) and a prominent method of congestion control. The intention is that the average rate of TFRC should be equivalent to the dominant protocol in the Internet, TCP. However, the short term TFRC rate is intended to be less aggressive than TCP as sharp fluctuations in coding rate will result in variable quality at the receiver. In that way, it is hoped that TFRC will avoid causing congestion collapse by greedy acquisition of bandwidth. In TFRC, the sending rate is made a function of the measured packet loss rate during a single round-trip time (RTT) duration measured at the receiver. Unfortunately, if the TFRC feedback frequency is reduced TFRC tends to dominate co-existing flows (Rhee et al., 2000). The sender then calculates the sending rate according to the TCP throughput equation given in (Handley et al., 2003). As with IT2 FLC and TEAR, the UDP transport protocol is employed to avoid unbounded delays, which are possible with TCP transport.

No control			
No. of Sources	Loss rate (%)	Link use (%)	PSNR (dB)
25	0.0	100.0	-
30	16.66	120.0	-
35	28.56	140.0	-
40	37.49	160.0	-
45	44.44	180.0	-
50	49.99	200.0	-
TFRC			
No. of Sources	Loss rate (%)	Link use (%)	PSNR (dB)
25	1.50	101.48	36.08
30	1.81	101.80	35.11
35	2.11	102.80	33.78
40	2.39	102.44	33.07
45	2.65	102.78	31.34
50	2.91	102.96	30.18
TEAR			
No. of Sources	Loss rate (%)	Link use (%)	PSNR (dB)
25	2.50	102.52	33.27
30	3.51	103.60	32.34
35	4.61	104.80	31.56
40	5.75	106.08	30.70
45	6.86	107.36	29.61
50	7.91	108.56	28.78
IT2 FLC			
No. of Sources	Loss rate (%)	Link use (%)	PSNR (dB)
25	0.0	89.82	39.61
30	0.0016	99.96	37.90
35	0.0026	99.96	36.89
40	0.0029	99.96	35.44
45	0.0038	99.84	33.19
50	0.0048	99.82	31.40

Table 2. Performance comparison of congestion controllers

Unlike TFRC, TEAR is based on the Arithmetic Increase Multiplicative Decrease (AIMD) algorithm of TCP. Unlike TCP, TEAR avoids the oscillatory behavior of TCP by averaging its sending rate over a round, based on the time to send a congestion window's packets. TEAR's sending rate approximates that of an equivalent TCP source. Both TFRC and TEAR rely on measurements of the RTT, while TFRC is also adversely affected by inaccurate loss rate estimates (Rhee et al., 2007). Without a transcoder TFRC and TEAR require playout buffers to smooth out network delay. Therefore, PSNR is affected by loss rate only, assuming a large enough buffer to avoid overflow. FLC also reduces the video quality

through transcoding if there is insufficient bandwidth, but this avoids the need for long start-up delays and allows smaller buffers on mobile devices. In further comparison tests, the standard 'dumbbell' network topology was assumed with a bottleneck of 25 Mbps. The one-way delay, modeling the latency across the complete network path, was set to 40 ms, which is the same as the maximum delay across a country such as the U.K or France. Side link delay was set to 1 ms and the side link capacity was set to easily cope with the input video rate. The mean encoded video rate was again 1 Mbps. The buffer size on the intermediate routers was set to $RTT \times \text{bandwidth}$, to avoid overflow through too small a buffer. The router queuing discipline was drop-tail. The intention of these tests was to see how many video streams could be accommodated across the bottleneck link. In Table 2, the number of controlled video sources was incrementally increased.

The starting times of streaming the 'news clip' to each client was staggered, and then each clip was repeatedly sent over 200 ms. The first 40 s of results, was discarded as representing transient results. This method was chosen, rather than select from different video clips, because the side effects of the video clip type do not intrude.

As can be seen from Table 2, when there is no control, there is no packet loss until the capacity of the link is reached. Thereafter, the link utilization grows and, as might be expected, the packet loss rate rapidly climbs. Failure to estimate the available bandwidth causes both TFRC's and TEAR's mean link use to exceed the capacity of the bottleneck link. As the number of flows increases, it becomes increasingly difficult to control the flows and there is a steady upward trend in the overshoot. In respect to TEAR, this leads to considerable packet loss. The packet loss patterns are reflected in the resulting PSNRs, though there is no direct relationship because of the effect of motion estimation in the codec. It is surprising in that TEAR was developed after TFRC and in part as a reaction to it (Rhee et al., 2007). However, subsequent to the development of TEAR, TFRC has undergone some refinements such as TCP's self-clocking. However, from Table 2 it is apparent IT2 FLC congestion control does not suffer from the difficulties that TFRC and TEAR encounter. There is a very small loss rate due to moments when the time varying nature of VBR video results in the FLC overestimating the available bandwidth but this is significantly below the loss rates of the traditional controllers.

4. Statistical multiplexing

4.1 IPTV and statistical multiplexing

Fortunately, compressed video streams forming the TV channels making up the IPTV service will not necessarily have the same bandwidth requirements, as their content complexity will vary over time with changes in their spatial and temporal complexity. In the long term, for entertainment applications this variation is determined by the video genre, such as sport, cartoon, 'soap' and so on but there are also changes over a shorter time period caused by such factors as the type of video frame and whether there is a shot change or a scene cut. Consequently, multiple video streams as part of an IPTV service can each be adaptively allocated a proportion of the bandwidth capacity according to their content complexity.

As IPTV bandwidth may be constrained by a particular access network technology a practical solution, which has already been developed in the UK and Japan (Kasai et al., 2002), is to employ a transcoder bank to change the rates of video streams within the

multimedia channel. Transcoders can dynamically and selectively change the compression ratio of individual pre-encoded video streams within a multimedia channel. However it is accomplished, the process of adjusting the rates of individual video streams is called statistical multiplexing.

Transcoding is a normal procedure in statistical multiplexing (Eleftheriadis & Batra, 2006) whereby the input streams can be adapted to fit the video display terminal. The coding complexity measures are computed based respectively on the transform coefficient and motion vector information embedded in each input bitstream, representing the compressed video. This information can be easily obtained just after the first decoding stage of the transcoder, *i.e.* after entropic decompression.

Though research (He & Wu, 2008) has experimented with statistical multiplexing of VBR streams, the practical reality is that broadcasters may often employ a CBR multiplex of streams (Bórczy et al., 1999) previously stored at a high quality. This is because CBR encoding allows planning of storage capacity and in video-on-demand schemes, it allows the bandwidth from a server to be tightly controlled. If the CBR video is not pre-encoded at a high rate (prior to transcoding) then dissolves, fast 'action' and scenes with camera motion (pans, zooms, tilts, ...) suffer. However, scenes with limited motion such as head-and-shoulder news sequences are not much affected by CBR encoding.

4.2 Statistical multiplexing gain

The revenue that can be potentially generated from combining video streams within a multimedia channel (Seeling & Reisslein, 2005) is related to the quality of the video delivered to the end users. In (Kuhn & Antkowiak, 2000) tests of a statistical multiplexor for Digital Video Broadcasting (DVB-T) (MPEG-2 encoded bitstreams) showed that multiplexing did not necessarily increase the number of TV channels that could be accommodated within a fixed bandwidth *but* did serve to avoid deep quality fades.

Allocating bandwidth to video streams simply on the basis of efficient usage and fair distribution of bandwidth (Jain et al., 2000) is not to be recommended, because the delivered video quality of some video streams will be more affected by a reduction in bandwidth than by others. Both unwarranted degradation of quality and unnecessarily high video quality may arise. This is also the reason why allocating bandwidth based on the past statistics of data rates may be ill-advised, as it fails to account for the impact of such allocations on the delivered video quality. R-D curves of video sequences significantly differ in their video quality at a particular CBR target bit-rate. Statistical multiplexing requires dynamic adjustment of the bandwidth share between several concurrent streams based upon the content complexity in order to equalize their delivered video quality. Ideally, the quality of all video streams will then fall within an acceptable range, being neither too high nor too low in quality.

From an R-D plot of three video sequences, Figure 9, it is apparent that there is a significant difference between the quality ratings of the videos. Therefore, the goal of statistical multiplexing is to adjust the quality between the streams relative to their content complexity rates over time. Good quality video normally falls within the range of 30-38 dB. At an initial target input rate of 1 Mbps, the quality of Mobile in Figure 9 is on the boundary of that range, while the quality of both Highway and Bridge-closed exceeds the range.

Statistical multiplexing techniques vary according to their complexity. In the research reported in (Wang & Vincent, 1996) a relatively simple form of statistical multiplexing was

applied in which the same quantization parameter was applied to all video frames within a multiplexed group to achieve a target bit rate. A binary chop search across the range of available quantization parameters was conducted. This procedure appeared to achieve its objective even though no direct account was taken of content complexity. The work in (Bóróczy et al., 1999) was based on coding complexity statistics was applied to a set of R-D controlled MPEG-2 video encoders. Only spatial coding complexity was considered and, therefore, no control was needed to include temporal complexity, at a cost in accuracy. Because encoders were employed, a look-ahead scheme was needed. This suffers from the problem of video scene changes occurring within a GOP inspection window, as the complexity may change significantly within a GOP. Some allowance for this problem was made by a sliding window GOP prediction method. The alternative is to partially decode future frames, as occurs in (He & Wu, 2008) for VBR video. Unfortunately, in (He & Wu, 2008), only the temporal complexity measure is found by partial decode, while the spatial complexity is predicted from a previous frame.

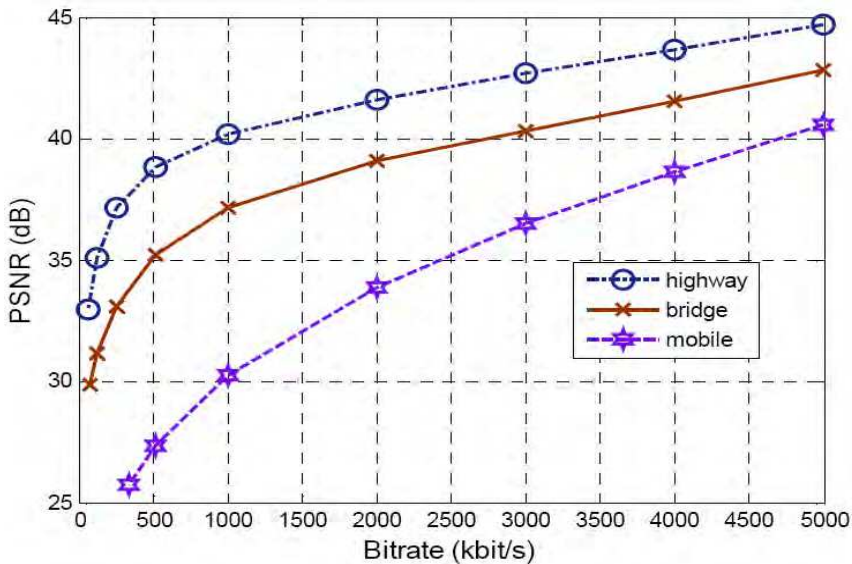

Fig. 9. R-D curves for three well-known video sequences.

In the statistical multiplexing system considered in this Chapter, R-D analysis is turned on in the H.264 encoder so that all rate decisions are optimized according to their effect on video quality. Moreover the problem of look ahead is resolved by directly transcoding each video stream GOP according to the joint estimation without the need for complex forward inspections of complexity (two-pass encoding) or potentially erroneous predictions.

4.3 Statistical multiplexing system

A top-level system diagram is presented in Figure 10. This is a suggested application of the scheme to illustrate a statistical multiplexing system. In this Figure, the statistical multiplexor receives n compressed bitstreams that pass through a bank of bit-rate

transcoders to adjust the combined bitrate according to the output channel constraints. The bandwidth share is defined by the statistical bandwidth manager which receives content complexity measure *parameters* from each transcoder and returns the appropriate bandwidth share a .

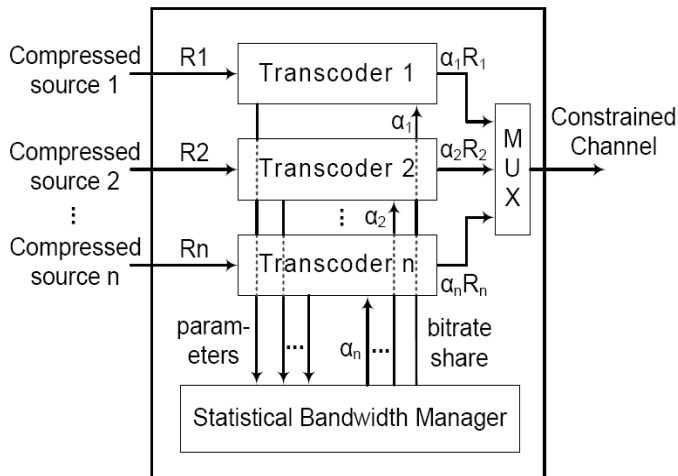

Fig. 10. A statistical multiplexor architecture

To reduce decision latency and to create a more direct way of judging the content complexity, metrics can be derived from the encoded bit-stream. Entropy decoding is required but this is a small overhead compared to a full decode. For example in the H.264/Advanced Video Codec (AVC), the Context Adaptive Variable Length (CAVLC) decode and bit-stream parsing on average take only 13% of the computational complexity of a full decode (Malvar et al., 2003).

Two metrics can be employed: temporal complexity index (TI) is indicated by a count of per frame non-zero motion vectors summed across a GOP, whereas spatial complexity can be found (Rosdiana & Ghanbari, 2000) by averaging a Scene Complexity Index (SCI) across the GOP. It is also possible to make decisions at scene change boundaries or through a GOP-sized sliding window at a cost in complexity but with a gain in reaction time. Because a large proportion of the bit-stream's length at higher video qualities is contributed to by quantized Discrete Cosine Transform (DCT) coefficients, the weighting given to the SCI metric is increased through the decision rules of an FLC. For a low bitrate service across a wireless channel then the impact of the motion vector coding would compete (Van der Auwera et al., 2007) with the quantized motion vectors, and it would become necessary to adjust the weighting between TI and SCI.

From the input video streams (coded in CBR mode) the average quantization parameter (QP) per frame is defined by the target bit rate. Consequently, multiple video streams sharing the channel can each be allocated a proportion of the bandwidth capacity according to their instantaneous spatial and temporal complexity. The target output rate of the video streams can be changed accordingly at a transcoder after each decision point (every GOP).

A FLC solves the problem of combining the two complexity indexes employed into a single bandwidth allocation ratio. Additionally, the FLC also receives notice of the bandwidth capacity. In the example illustrated in this Section, the final access link is assumed to be ADSL. However, ADSL is subject to burst errors following the Repetitive Electrical Impulse Noise (REIN) model (Luby et al., 2008). Once the FLC has determined the ratio allocated to each video stream sharing the IPTV multimedia sub-channel, the video bitstream rates are jointly adjusted by bitrate transcoders.

4.4 Experimental evaluation

For tests, 900 frames from the three well-known sequences of Figure 9 were selected with content complexity category estimated as difficult, medium, and easy. The JM v. 14.2 software implementation of the H.264/AVC codec was used with Common Intermediate Format (CIF)-30 Hz (frame/s)@ 5 Mbps, 4:2:0 sampling, and GOP size of 15. An IPPP... GOP structure was set with Instantaneous Decoder Refresh (IDR) frames configured. R-D control was set for the CBR output with initial quantization parameter (QP) at 28 and only 4x4 DCTs.

Figure 11 is a plot of the per GOP number of non-zero motion vectors over time. For ease of representation, an average of the first 20 GOPs is plotted, though naturally the entire 60 GOP sequences were examined. The TI measure for 'Mobile' fluctuates over time within this short excerpt, though recall that the TI emphasis is reduced in the FLC compared to the SCI. Figure 4 is a matching plot for the SCI over time. In general, the SCI is found as:

$$SCI = \frac{1}{1 + p + b} \left[IQ_I + \sum_{j=1}^p P_j QP_j + \sum_{i=1}^b B_j QB_i \right] \quad (6)$$

where p , b are the number of P and B pictures per GOP respectively and QI , QP and QB are the respective average (over the picture's macroblocks) quantizer step sizes for the I, P, and B pictures. I, P and B are the corresponding per picture type target bit-rates. Again, in Figure 12 it is the Mobile sequence that shows the most fluctuation. Alternative metrics are: 1) employing QP values into (6) to take account of the changing dynamic range of the allocations and 2) using the numbers of non-zero coefficients

Figure 13 shows the input PSNRs for the three sequences, showing fluctuations in behavior. As PSNR is best-suited to quality comparisons for the same video sequence coded at different rates, PSNR comparisons are made between equal allocation and statistical multiplexing and should not involve direct comparison of the quality between different video streams. Statistical multiplexing decisions are made on the basis of content complexity and do not involve PSNR.

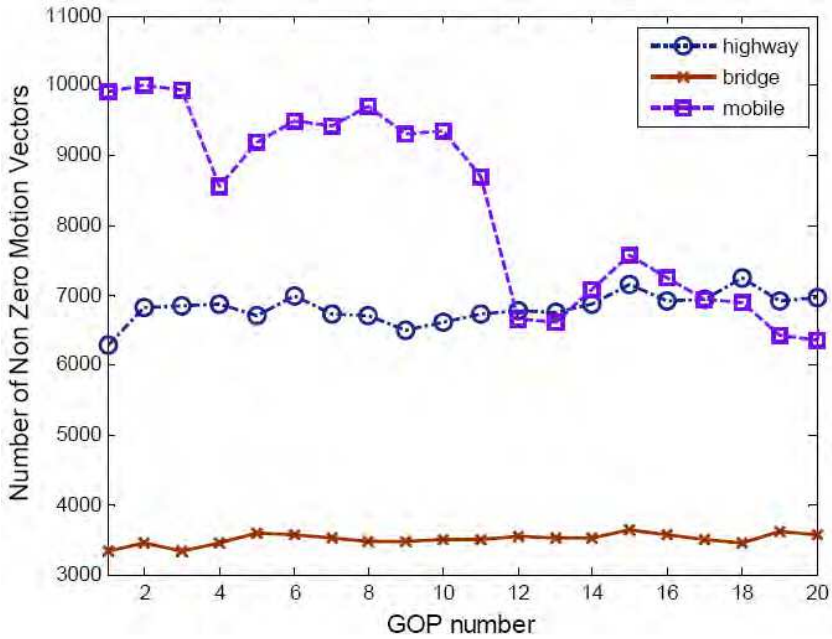

Fig. 11. Number of non-zero motion vectors on a GOP basis

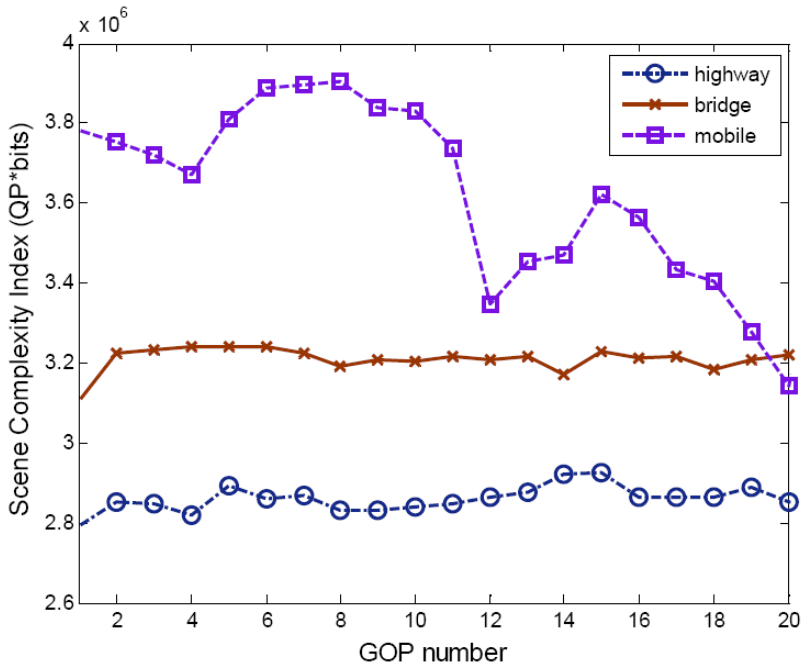

Fig. 12. Scene Complexity Index (SCI) on a GOP basis

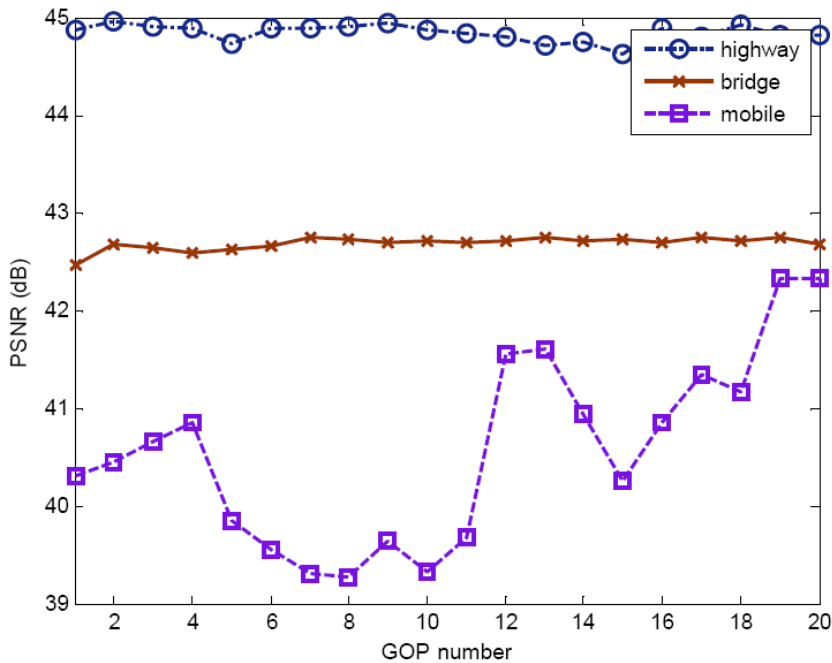

Fig. 13. PSNR fluctuation of input test sequences

In tests, packetisation was on the basis of one H.264 NALU per packet, with each row forming a slice to be encapsulated in a NALU. Error-free, fixed bandwidth (3 Mbps) allocation is firstly considered. (If the access link is cable or even a passive optical network (PON), the physical channel will be virtually error free and the bandwidth capacity will effectively be fixed.) Figure 14 shows the time-wise allocation of bandwidths after application of the FLC based on the SCI and TI metrics. The allocation follows approximately the content complexity of the test clips, in the sense that a more complex sequence receives a larger proportion of bandwidth. Figure 15 is a histogram of the per-frame frequencies for which the video sequences fell within the desired quality range (30-38 dB), compared to the same allocation if no adjustment to the initial CBR rates was made.

The allocation over time is illustrated for Highway in Figure 16. Table 3 summarizes the average video qualities resulting from the FLC and equal CBR allocations. It is apparent that for Mobile much of the time the FLC allocation results in a higher video quality than a CBR scheme would do, whereas for Highway and Bridge-closed, the video quality (which is already high) is somewhat reduced.

In (Luby et al., 2008), the REIN model for ADSL was applied to IPTV. This is a simple model of fixed-length error bursts, the duration of which was set to 8 ms. The bursts were randomly placed to achieve a loss rate in the range 5×10^{-2} to 5×10^{-3} . In (Luby et al., 2008), a larger error range was simulated but at the lower ends of that range the error rate was effectively close to being error free.

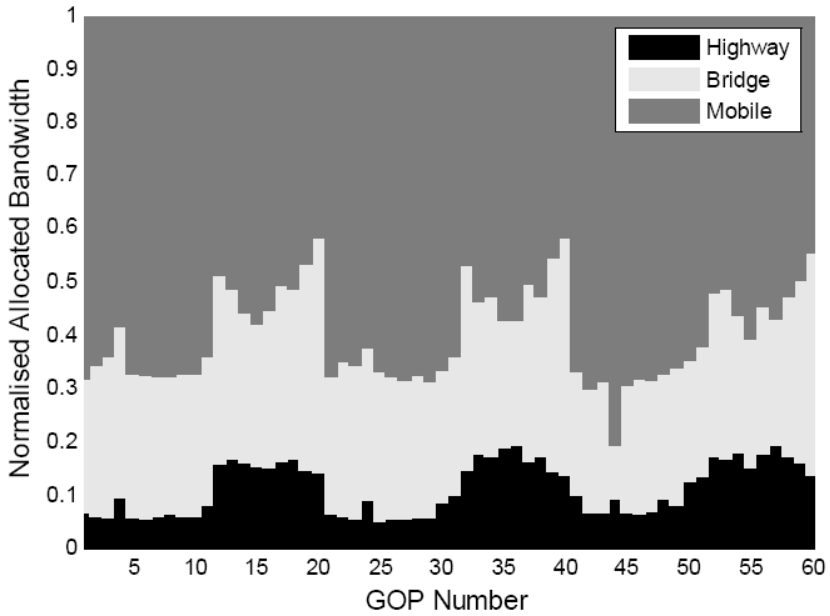

Fig. 14. Bandwidth allocation share per GOP with FLC controller

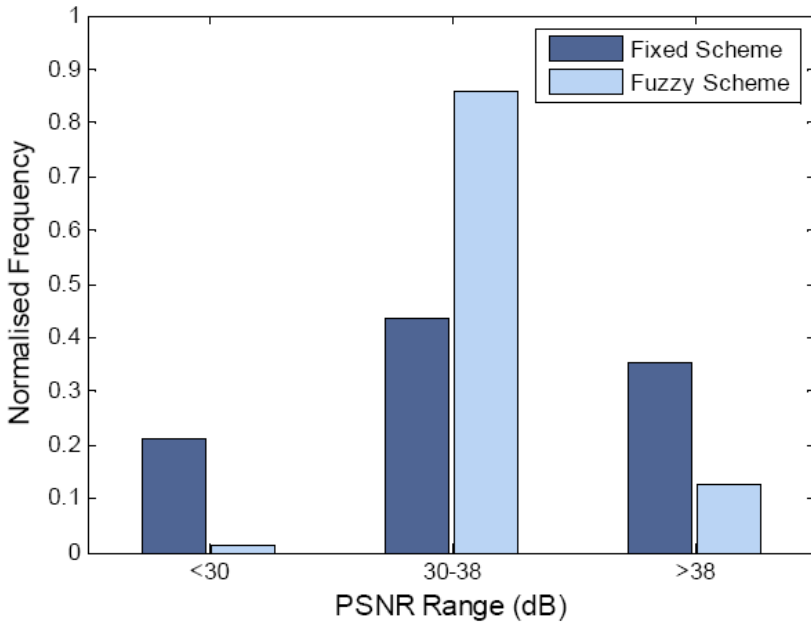

Fig. 15. Normalized per-frame frequencies of video quality for which the three test clips kept within a desired quality range for FLC and equal (fixed) CBR allocation bandwidth

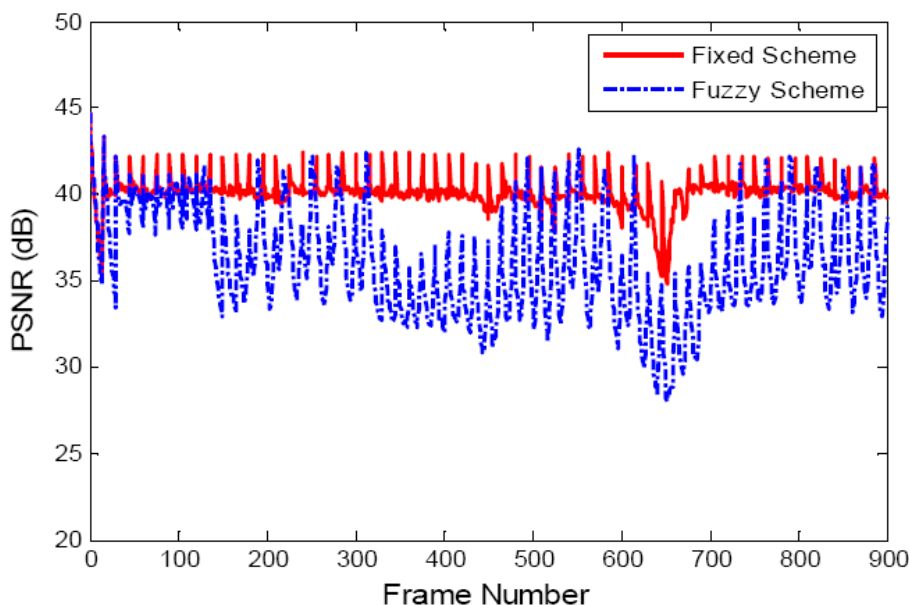

Fig. 16. Comparative video quality over time achieved for Highway between FLC and equal CBR (fixed) schemes

	FLC		CBR	
	Bitrate (kbps)	PSNR (dB)	Bitrate (kbps)	PSNR (dB)
Bridge	338.51	36.03	1000	40.60
Highway	857.01	36.62	1000	36.96
Mobile	1802.90	32.53	1000	29.61

Table 3. Summary results of comparative bandwidth allocation between FLC and equal CBR schemes with fixed available

The effect of physical channel degradation on video according to the REIN model for ADSL was ascertained for a fixed available bandwidth (of 3 Mbps), after subsequent distribution of the video streams to individual users. Figure 17 reports the relative video quality between equal CBR share and FLC allocation. In Figure 17, each data point is the result of forty runs in order to achieve convergence. In particular, the video quality of Mobile is improved by the FLC allocation. This Figure shows that the quality of difficult sequences like Mobile is improved at the expense of degradation on the easier sequences like Highway resulting in a balance between the quality of the quality of multiplexed video. At higher Bit Error Rates (BERs), Mobile’s quality becomes poor in both schemes, though the CBR allocation can result in unwatchable TV. Perhaps, a weakness of the FLC allocation is that Highway also drops out of the desired quality range, though at high BERs.

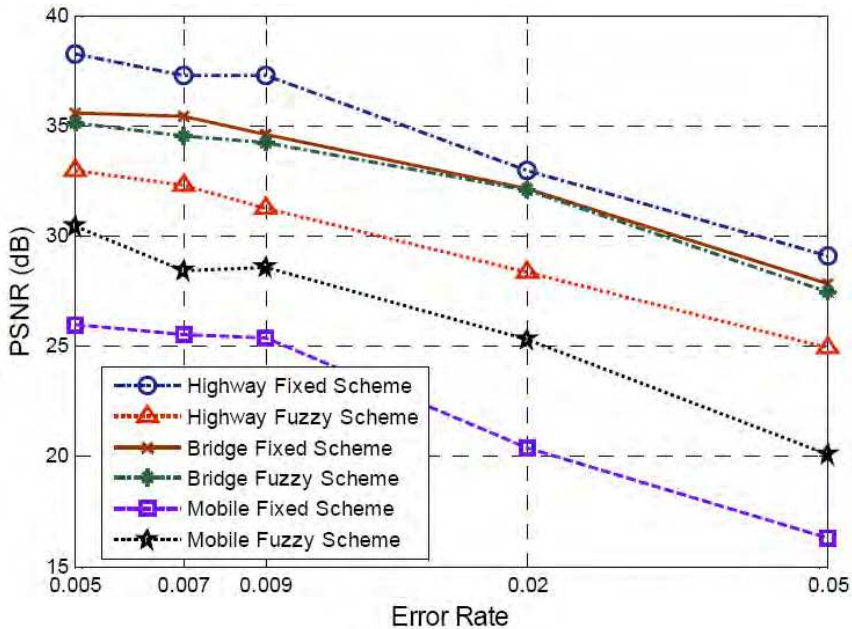

Fig. 17. Video quality according to FLC and equal CBR (fixed) schemes for the ADSL REIN model.

Statistical multiplexing aims to equalize the quality of a set of video streams sharing a common multimedia channel. The quality should also, as far as possible, fall within an acceptable range. The danger of statistical control of data rates is that it does not take account of the varying content complexity of video streams. However, dynamic adjustments can be jointly made to the target video data rates in response to prior input of spatial and temporal compression metrics. These can be extracted from the encoded bitstream just after entropic decode and simple parse operations. Fuzzy logic control subsequently serves to tune the impact of each of the metrics.

5. Concluding remarks

This Chapter has been an introduction to video streaming, from a particular perspective in which intelligent control methods increasingly handle congestion and allocation of bandwidth through statistical multiplexing. Though download undoubtedly has a role in activities such as multimedia podcasting and BitTorrent film downloads, there are always streaming alternatives, which in time may take over from the era of the download, with its inefficient bandwidth consumption. These alternatives range from: enhanced-quality IPTV; user-generated YouTube content; and P2P streaming systems such as PPLive and Coolstreaming, which have a strong following in China; and varieties of mobile TV, such as DVB-H. The demand for bandwidth is increasing as this year (2009) has seen the first High Definition mobile devices. This development is logical as a closer viewing distance strictly requires greater resolution. However, the move to higher resolution reduces the ability of

the user to store locally compressed video. In fact, the desire to own a DVD film just as books are owned and kept in a library may also decline.

6. References

- Assunção, P.A.A. & Ghanbari, M. (1997). Congestion Control of Video Traffic with Transcoder, *Int. Conf. on Image Processing*, pp. 523-527
- Assunção, P.A.A. & M. Ghanbari (2000). Buffer analysis and control in CBR video transcoding, *IEEE Trans. on Circuits and Systems for Video Technology*, Vol. 10, No. 1, pp. 83-92
- Barmada, B.; Ghandi, M. M.; Jones, E.; & Ghanbari, M. (Aug. 2005). Prioritized transmission of data partitioned H.264 video with hierarchical QAM, *IEEE Signal Proc. Lett.*, Vol. 12, No. 8, pp. 577-580
- Bórczy, L.; Ngai, A. Y. & Westermann, E. F. (1999). Statistical multiplexing using MPEG-2 video encoders, *IBM J. of Research and Development*, Vol. 43, No. 4, pp. 511-520
- Blakowski, G. & Steinmetz, R. (Jan. 1996). A media synchronization survey: Reference model, specification, and case studies, *IEEE J. on Selected Areas in Comms.*, Vol. 14, No. 1, pp. 9-33
- Chou, P. A.; & Miao, Z. (April 2006) Rate-distortion optimized streaming of packetized media, *IEEE Trans. on Multimedia*, Vol. 8, No. 2, pp. 390-404
- Chou, P. A. (2007). Streaming media on demand and live broadcast , in P. A. Chou and M. van der Schaar (Eds.) *Multimedia in IP and Wireless Networks*, Academic Press, Burlington, MA, pp. 453-501
- Cisco Systems, Inc. (2000). LAN design guide for the midmarket, San Jose, CA
- Eleftheriadis, A. & Batra, P. (April 2006). Dynamic rate shaping of compressed digital video, *IEEE Trans. on Multimedia*, Vol. 8, No. 9, pp. 297-314
- Fleury, M.; Razavi, R.; Saleh, S.; Al-Jobouri, L. & Ghanbari, M. (2009). Enabling WiMAX video streaming, In *WiMAX, New Developments*, In-Tech Education and Publishing, Vienna, Austria
- Ghanbari, M. (2003). *Standard Codecs: Image Compression to Advanced Video Coding*, IET Press, London, UK
- Geer, D. (Nov. 2005). Building converged networks with IMS technology, *IEEE Computer*, Vol. 38, No. 11, pp. 14-16
- Grant, P. M.; Saw, Y.-S. & J. M. Hannah, J. M. (June 1997). Fuzzy rule-based MPEG rate prediction and control, *EURASIP ECAS Conf.*, pp. 211-214
- Hagras. H. (Feb. 2007). Type-2 FLCs: A new generation of fuzzy controllers, *IEEE Computational Intelligence*, pp. 30-43
- Han, S.; Lisle, S. & Nehib, G. (Feb. 2008). IPTV transport architecture alternatives and economic considerations, *IEEE Comms. Mag.*, Vol. 46, No. 2, pp. 70-77
- Handley, M.; Floyd, S.; Padyhe, J. & Widmer, J. (2003). TCP friendly rate control (TFRC): Protocol specification, IETF RFC 3448
- He, Z. & Wu, D. O. (Nov. 2008). Linear rate control and optimum statistical multiplexing for H.264 video broadcast, *IEEE Trans. Multimedia*, Vol. 10, No. 7, pp. 1237-1249
- IEEE 802.16-2004, (Oct. 2004). IEEE Standard for local and metropolitan area networks part 16: Air interface for fixed broadband wireless access systems

- Jain, R.; Kalyanaraman, S.; Goyal, R.; Fahmy, S. & Viswanathan, R. (Aug. 2000). ATM forum document number: ATM forum/96-1172 title: Erica switch algorithm: A complete description
- Jammeh, E. A.; Fleury, M. & Ghanbari, M. (April 2007). Delay-based congestion avoidance for video communication with fuzzy logic control, *17th Int. Workshop on Packet Video*
- Kalman, M.; Steinbach, E. & Girod, B. (Sept. 2002). Adaptive media playout for low delay video streaming over error-prone channels, *Int. Conf. on Image Processing*, pp. 841-851.
- Kasai, H. et al. (Oct. 2002). The development of a multimedia transcoding system for mobile access to video conferencing, *IEICE Trans. on Communications*, Vol. 10, No. 2, pp. 2171-2181
- Kim, I.-M. & Kim, H.-M. (2002). A new resource allocation scheme based on a PSNR criterion for wireless video transmission to stationary receivers over Gaussian channels., *IEEE Trans. on Wireless Commun.*, Vol. 2, No. 3, pp. 1320-1324
- Kuhn, M. & Antkowiak, J. (Apr. 2000). Statistical multiplex what does it mean for DVB-T?, *FKT Fachzeitschrift für Fernsehen, Film und elektronische Medien*
- Lakshman, T.; Ortega, A. & Reibman, A. (May 1998). VBR video: tradeoffs and potentials, *Proc. of the IEEE*, Vol. 86, No. 5, pp. 952-973
- Lambert, P.; de Neve, W.; Dhondt, Y. & van de Walle, R. (2006). Flexible macroblock ordering in H.264/AVC, *J. of Visual Communication*, Vol. 17, pp. 358-375
- Lefol, D.; Bull, D. & Canagarajah, N. (2006). Performance evaluation of transcoding algorithms for H.264, *IEEE Trans. on Consumer Electronics*, Vol. 52, No. 1, pp. 215-222
- Luby, M.; Stockhammer, T. & Watson, M. (May 2008). Application FEC in IPTV systems, *IEEE Commun. Mag.*, Vol. 46, No. 5, pp. 94-102
- Malvar, H.; Hallapuro, A.; Karczewicz, M. & Kerofsky, L. (July 2003). Low complexity transform and quantization in H.264/AVC, *IEEE Trans. on Circuits Syst. Video Technol.*, Vol. 13, No. 7, pp. 598-603
- Mackay, D. J. C. (2005). Fountain codes, *IEE Proc. on Communications*, Vol. 152, No. 6, pp. 1062-1068
- Mao, S.; Lin, S.; Panwar, S. S.; Wang, Y. & Celebi, E. (2003). Video transport over ad hoc networks: multistream coding with multipath transport, *IEEE J. on Selected Areas in Comms.*, Vol. 21, No. 4, pp. 1721-1737
- Mendel, J. M. (Feb. 2007) Type-2 fuzzy sets and systems: An overview, *IEEE Computational Intelligence*, pp. 20-29
- Pesquet-Popescu, B.; Li, S. & van der Schaar, M. (2007). Scalable video coding for adaptive streaming applications, in P. A. Chou and M. van der Schaar (Eds.) *Multimedia in IP and Wireless Networks*, Academic Press, Burlington, MA, pp. 117-158
- Radha, H.; van der Schaar, M.; Chen, Y. (Mar. 2001). The MPEG-4 Fine_Grained Scalable video coding method for multimedia streaming over IP, *IEEE Trans. on Multimedia*, Vol. 3, No. 1, pp. 53-68
- Rezaei, M.; Hanukse, M. M. & Gabbouj, M. (2008). Semi-fuzzy rate controller for variable bit rate video, *IEEE Trans. on Circuits and Systems for Video Technology*, Vol. 18, No. 5, pp. 633-645
- Rhee, I.; Ozdemir, V. & Yi, Y. (April 2000). TEAR: TCP emulation at receivers – flow control for multimedia streaming, *NCSU Technical Report*

- Rhee, I. & Xu, L. (2007) Limitations of equation-based congestion control, *IEEE/ACM Trans. on Networking*, Vol. 15, No. 4, pp. 852-865
- Rosdiana, R. & Ghanbari, M. (Mar. 2000). Picture complexity based rate allocation algorithm for transcoded video over ABR networks, *Electronics Letters*, Vol. 36, No. 6, pp. 521-522
- Salehi, J.; Zhang, Z.-L.; Kurose, J. & Towsley, D. (Aug. 1998). Supporting stored video: Reducing rate variability and end-to-end resource requirements through optimal smoothing, *IEEE/ACM Trans. on Networking*, Vol. 6, No. 4, pp. 397-410
- Schulzrinne, H.; Rao, A. & Lampeter, R. (April 1998) Real time streaming protocol (RTSP), proposed standard RFC 2326
- Seeling, P. & Reisslein, M. (Dec. 2005). The rate variability-distortion (VD) curve of encoded video and its impact on statistical multiplexing, *IEEE Trans. Broadcast.*, Vol. 51, No. 4, pp. 473-492
- Shokrollahi, A. (2006). Raptor codes, *IEEE Trans. on Information Theory*, Vol. 53, No. 1, pp. 2551-2567
- Stockhammer, T. & Zia, W. (2007). Error-resilient coding and decoding strategies for video communication, in P. A. Chou and M. van der Schaar (Eds.) *Multimedia in IP and Wireless Networks*, Academic Press, Burlington, MA, pp. 13-58
- Sun, H.; Chen, X. & Chiang, T. (2005). *Digital Video Transcoding for Transmission and Storage*, CRC Press, New York
- Van der Auwera, G.; Reisslein, M. & Karam, L. J. (Sept. 2007). Video texture and motion based modelling of rate variability-distortion (VD) curves, *IEEE Trans. on Multimedia*, Vol. 53, No. 3, pp. 637-648
- Van der Auwera, G.; David, P. D. & Reisslein, M. (Sept. 2008). Traffic and quality characterisation of single layer video streams with the H.264/MPEG-4 Advanced Video Coding Standard and Scalable Video Coding extension, *IEEE Trans. on Broadcasting*, Vol. 54, No. 3, pp. 698-718
- Van der Auwera, G. & Reisslein, M. (to appear Sept. 2009). Implications of smoothing on statistical multiplexing of H.264/AVC and SVC video streams, *IEEE Trans. on Broadcasting*.
- Vasudevan, S.; Liu, X. & Kollmansberger, K. (May 2008). IPTV Architectures for Cable Systems: An evolutionary approach, *IEEE Comms. Mag.*, Vol. 46, No. 5, pp. 102-109
- Vars, V. and Hannuksela, M. N. (2001). Non-normative error concealment algorithms, ITU-T SG16 Doc., VCEG-N62
- Vetro, A.; Christopoulos, C. & Sun, H. (2005). Video transcoding architectures and techniques: An overview" *IEEE Signal Processing Mag.*, Vol. 20, pp. 18-29
- Wang, Y. & Zou, Q. F. (1998) Error control and concealment for video communication: A review. *Proceedings of the IEEE*, Vol. 86, No. 5, pp. 974-997.
- Wang, Y.; Reibman, A. R. & Lee, S. (2005). Multiple description coding for video delivery, *Proceedings of the IEEE*, Vol. 93, No. 1, pp. 57-70
- Wang, L. & Vincent, A. (Sept. 1996). Joint rate control for multi-program video coding, *IEEE Trans. Consumer Electron.*, Vol. 42, No. 3, pp. 300-305
- Wenger, S. (July, 2003) H264/AVC over IP, *IEEE Trans. on Circ. and Syst. for Video Technol.*, Vol. 13, No. 7, pp. 645-656
- Xie, G.; Zhang, G.; Yang, J.; Min, Y.; Issarny, V. & Conte, A. (June 2007). Survey on traffic of metro area network with measurement on-line, *Int. Teletraffic Congress*, pp. 666-677

- Zaddeh, L. A. (1975). The concept of linguistic variable and its application to approximate reasoning, *Information Sciences*, Vol. 8, pp. 199-249
- Zhang, L. et al. (Sept. 1997). Resource ReSerVation Protocol (RSVP), Request for Comment (RFC) 2205
- Zheng, H. & Liu, K. (July 2000). Multimedia services over digital subscriber lines, *IEEE Trans. Signal Processing*, Vol. 17, No. 4, pp. 44-60



Trends in Telecommunications Technologies

Edited by Christos J Bouras

ISBN 978-953-307-072-8

Hard cover, 768 pages

Publisher InTech

Published online 01, March, 2010

Published in print edition March, 2010

The main focus of the book is the advances in telecommunications modeling, policy, and technology. In particular, several chapters of the book deal with low-level network layers and present issues in optical communication technology and optical networks, including the deployment of optical hardware devices and the design of optical network architecture. Wireless networking is also covered, with a focus on WiFi and WiMAX technologies. The book also contains chapters that deal with transport issues, and namely protocols and policies for efficient and guaranteed transmission characteristics while transferring demanding data applications such as video. Finally, the book includes chapters that focus on the delivery of applications through common telecommunication channels such as the earth atmosphere. This book is useful for researchers working in the telecommunications field, in order to read a compact gathering of some of the latest efforts in related areas. It is also useful for educators that wish to get an up-to-date glimpse of telecommunications research and present it in an easily understandable and concise way. It is finally suitable for the engineers and other interested people that would benefit from an overview of ideas, experiments, algorithms and techniques that are presented throughout the book.

How to reference

In order to correctly reference this scholarly work, feel free to copy and paste the following:

Martin Fleury, Emmanuel Jammeh, Rouzbeh Razavi, Sandro Moiron and Mohammed Ghanbari (2010). Video Streaming in Evolving Networks under Fuzzy Logic Control, Trends in Telecommunications Technologies, Christos J Bouras (Ed.), ISBN: 978-953-307-072-8, InTech, Available from:
<http://www.intechopen.com/books/trends-in-telecommunications-technologies/video-streaming-in-evolving-networks-under-fuzzy-logic-control>

INTECH

open science | open minds

InTech Europe

University Campus STeP Ri
Slavka Krautzeka 83/A
51000 Rijeka, Croatia
Phone: +385 (51) 770 447
Fax: +385 (51) 686 166
www.intechopen.com

InTech China

Unit 405, Office Block, Hotel Equatorial Shanghai
No.65, Yan An Road (West), Shanghai, 200040, China
中国上海市延安西路65号上海国际贵都大饭店办公楼405单元
Phone: +86-21-62489820
Fax: +86-21-62489821